

## Line protective relays - types - operation

**Objectives:** At the end of this lesson you shall be able to

- state the classification of relays
- list the types of relays and their uses
- explain the principle of operation of over current, differential, earth fault, distance and non directional relays
- state the characteristics of relays
- explain the principle of operation of a over voltage end under voltage relay
- state the necessity of time multiplier setting of relay.

### Introduction

The relays is the element that senses as abnormal condition in the circuit and commands the operation of the breaker. It interpret the fault quantities ie, CT output current and PT output voltage and sending the command to the tripping circuits of breaker for operation in accordance with the characteristic set in the relay and the value of the time multiplier setting.

### Classification of Relays

**Relays are classified mainly in three categories; they are according to:**

- 1 **Quantity sensed :** Current, Voltage, active power, reactive power & impedance
- 2 **Tripping :** Instantaneous trip, delayed trip inverse time response and definite time
- 3 **Operating principle:** Electro magnetic relays, Induction relays, Thermal relays and static or digital relays

**Types or relays :** Various types of relays are used as per the requirement; they are:

- 1 Over current relay
- 2 Over voltage relay

- 3 Under voltage relay
- 4 Differential relay
- 5 Earth fault relay
- 6 Distance relay
- 7 Impedance relay
- 8 Admittance relay
- 9 Reactance relay

Relay is one of the main device used for switch gear protection networks to protect the transmission lines, transmission equipments and sub station equipments. The equipments used for transmission and in substation for distribution such as transformers, lightening arrestors, earth switches, isolators, CTs & PTs etc; are very costly and needs continuous protection from damage. Replacement or repairs are not easy and to provide an uninterrupted supply to consumers. So, protection of these devices/equipments are very essential

Reasons for over current, Over voltage and under voltage fault:

Many reasons constituted for over current, over and under voltage or earth faults; type of fault and the cause effect is listed in Table 1.

Table 1

SI No	Type of Fault	Cause	Effect
1	Phase to neutral short	<ul style="list-style-type: none"> <li>- Insulation failure</li> <li>- Components failure</li> <li>- Human error</li> </ul>	<ul style="list-style-type: none"> <li>- High current flow in line.</li> <li>- Fire</li> </ul>
2	Phase to phase short in transmission lines	<ul style="list-style-type: none"> <li>- Tree branches falls on line</li> <li>- Snakes crossing on tower lines and</li> <li>- Birds falls</li> <li>- Strong winds</li> <li>- Natural calamities</li> <li>- Riots, and human made faults</li> </ul>	<ul style="list-style-type: none"> <li>- Very high current flows</li> <li>- Fire</li> <li>- Extensive damage of equipments</li> </ul>
3	Phase to ground fault	<ul style="list-style-type: none"> <li>- Insulation failure</li> <li>- Component failure</li> </ul>	<ul style="list-style-type: none"> <li>- High current flow in line</li> <li>- Fire</li> <li>- Low voltage</li> </ul>

SI No	Type of Fault	Cause	Effect
4	Lightening storm etc;	- Natural calamities	- Very high current flows - Fire - High voltage spikes
5	Sudden removal of heavy load	- Fuse failure	- High voltage
6	Increasing Load beyond the rated level	- Human Error	- Low voltage in line - Overloading the line

### Sensors used for Relays

The relay cannot accept the total line voltage or load current. A small part of the electrical quantity is supplied to the relay through sensors. A current transformer popularly known as CT and a potential transformer PT, is serves the purpose of sensors in current relay and voltage relay. Various input and output ratios are in practice to supply the sensing quantity to the relays according to the load conditions.

### Working principle of current relay

The electro magnetic relay widely using in the substation and transmission lines are serves the protection from the disaster conditions. The latest version of modern static or digital relays are now a days out dated the conventional electro magnetic relays, because of their many of advancements compare to electro magnetic relay. (Fig 1)

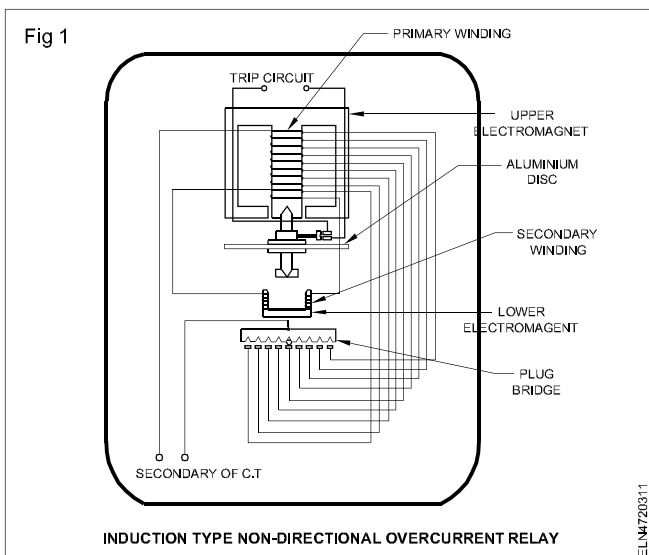
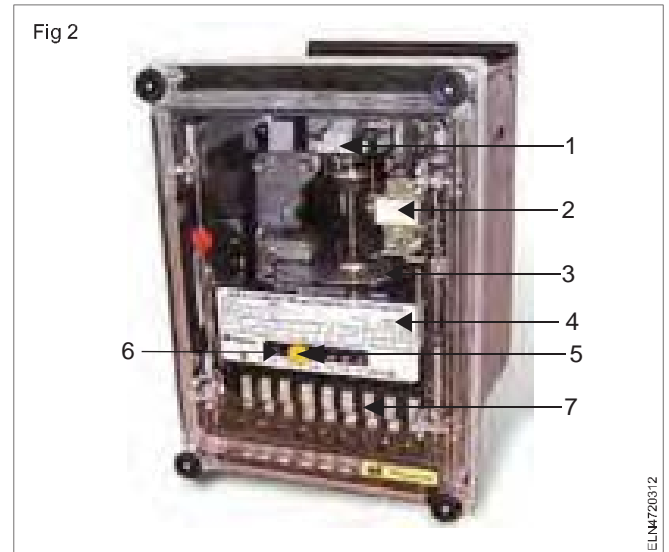

Fig 2 shows the front panel setting of a electric magnetic relay.

- 1 Time multiplier setting (TMS)
- 2 Trip flag
- 3 Aluminium rotating disc
- 4 Percentage fault quantity time reference dial



- 5 Tap setting plug
- 6 Input fault quantity ( $V_{ONI}$ )
- 7 Contact plug terminals

An induction type over current relay giving inverse time operation with a definite minimum time characteristic is in Fig 1. It consists essentially of an ac energy meter mechanism with slight modification to give required characteristics. The relay has two electromagnets. The upper electromagnet has two windings, one of these is primary and is connected to the secondary of a CT in the line to be protected and is tapped at intervals.

The tappings are connected to a plug setting bridge by which the number of turns in use can be adjusted, thereby giving the desired current setting. The plug bridge is usually arranged to give seven sections of tappings to give over current range from 50% to 200% in steps of 25%. If the relay is required to response for earth fault the steps are arranged to give a range from 10% to 70% or 20 to 80% in steps of 10%. The values assigned to each tap are expressed in terms of percentage of full-load rating of CT with which the relay is associated and represents the value above which the disc commences to rotate and finally closes the trip circuit.

Thus pick-up current equals the rated secondary current of CT multiplied by current setting. For example suppose

that an over current relay having a current setting of 150% is connected to a supply circuit through a CT of 500/5A. The rated secondary current of CT is 5A and, therefore, the pick-up value will be  $1.5 \times 5$  i.e., 7.5 A. It means that with above current setting, the relay will actually operate for a relay current equal to or greater than 7.5 A.

Similarly for current settings of 50, 100 and 200% the relay will operate for relay currents of 2.5A, 5 A and 10 A respectively. Adjustment of current setting is made by inserting a pin between the spring loaded jaws of the bridge socket at the tap value required. When the pin is withdrawn for the purpose of changing the setting value while the relay in service, the relay automatically adopts higher setting, thus the CT's secondary is not open-circuited.

The disc spindle carries a moving contact which bridges two fixed contacts (trip circuit contacts) when the disc has rotated through a preset angle. The angle can be set to any value between  $0^\circ$  and  $360^\circ$  and there by giving desired time setting. This adjustment is known as time-setting multiplier. Time multiplier setting is generally in the form of an adjustable back-stop which decides the arc length through which the disc travels, by reducing the length of travel, the operating time is reduced.

The time setting multiplier is calibrated from 0 to 1 in steps of 0.05. These figures do not represent the actual operating times but are multipliers to be used to convert the time known from the relay name plate curve (time-PSM curve) into the actual operating time. Thus if time setting is 0.2 and the operating time obtained from the time-PSM curve of the relay is 5 seconds, then actual operating time of the relay will be equal to  $0.2 \times 5$  i.e., 1 second.

Since the time required to rotate the disc through a preset angle depends upon the torque which varies as the current in the primary circuit, therefore, more the torque lesser will be the time required. So the relay has inverse-time characteristic.

## Relay Time setting characteristics

### 1 Instantaneous over current/voltage relay

Definite current/voltage (over or under) relay operate instantaneously when the fault quantity reaches a predetermined value. (Fig 3)

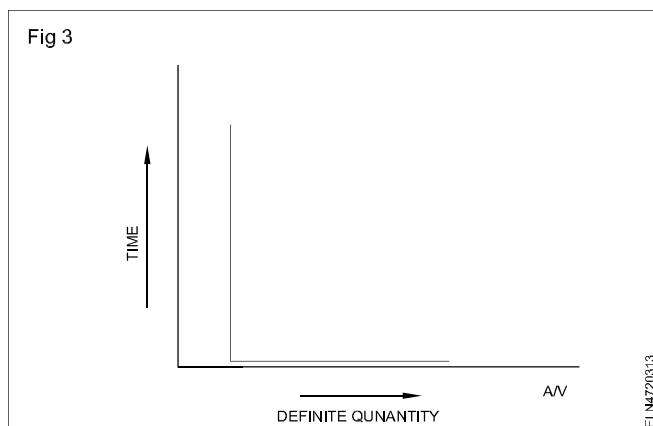

- Operates in a definite time when fault quantity exceeds its pick-up value.
- Its operation criteria is only fault quantity magnitude
- Operating time is constant
- No intentional time delay
- These are varies with position of the fault occurred because of the difference in impedance between the fault and the source
- It can operates in 0.1s or less.

### 2 Definite time

Two conditions must be satisfied on the fault quantity continued to be present up to the time setting of the relay. (Fig 4)

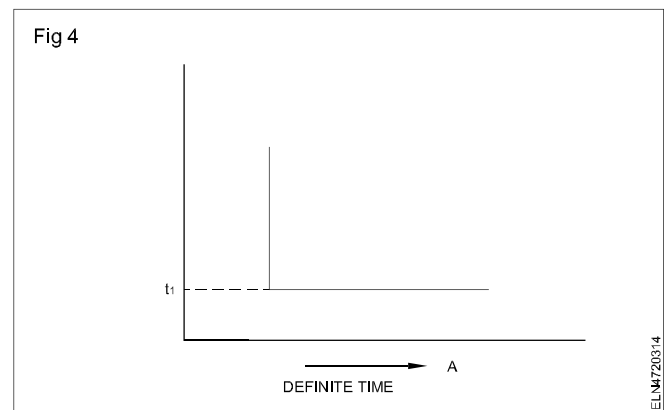

- Its operating time is constant
- Its operation is independent of the magnitude of the fault quantity
- It has time dial settings; Time delay can be varied
- Tripping time independent on fault location.

### 3 Inverse time

Operating time is inversely changed fault quantity. So, high the fault quantity will operate relay faster than lower ones (Fig 5). There are few more settings also in practice, They are;

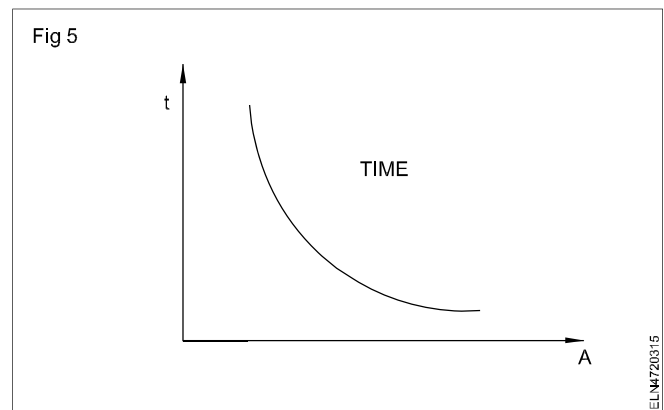

- Standard inverse
- Very inverse
- Extremely inverse

Discrimination by both time and fault quantity, the relay operation time is inversely proportional to the fault quantity.

Inverse time relays also referred as Inverse Definite Minimum Time (IDMT) relays.

The operating time of relay can be moved up (made slower) by adjusting the time dial setting. The lowest time dial setting (fastest operating time) is generally 0.5 seconds and the slowest is 10s.

### Silent features of inverse time settings

- Operates when fault quantity exceeds its pick-up value.
- Operating time depends on the magnitude of the fault quantity
- It gives inverse time current characteristics at lower values of fault quantity and definite time characteristics at higher values.
- An inverse characteristics is obtained if the value of plug setting multiplier is below 10, for values between 10 and 20 characteristics tends towards definite time characteristics. Fig 6 shows the different inverse types. Based on the inverseness it has three different types of curves shown in Fig 6.

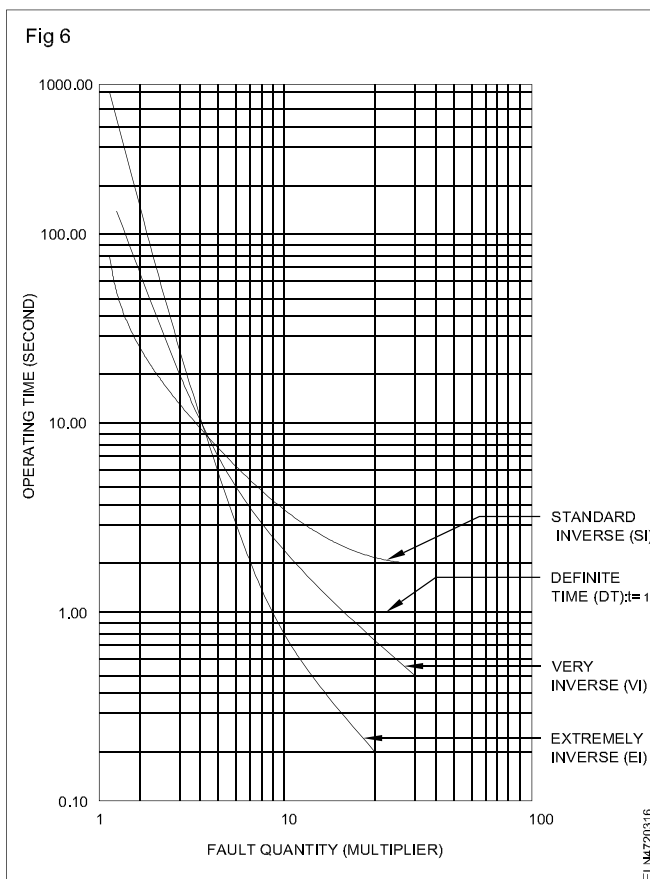

### Normal Inverse Characteristics

The accuracy of the operating time may range from few percentage of the nominal operating time. The uncertainty of the operating time and the receiving operating time may require a grading margin of less than one seconds.

Normal inverse time over current relay is relatively small change in time/unit of change of current

### Very inverse time characteristics

- Gives more inverse characteristics than that of IDMT
- Used when there is a reduction in fault quantity, as the distance from source increases
- Effective with ground faults because of their steep characteristics
- Suitable where the fault distance from the power source increase
- Particularly suitable if the short circuit fault current drops rapidly with the distance from the substation
- The grading margin may be reduced to very low time (0.1 second) in this characteristics
- Used when fault quantity is dependent on fault location

### Extremely inverse time characteristics

- It has more inverse characteristics than that of IDMT and very inverse characteristics
- Suitable for protection against over heating
- Operative time approximately inversely proportional to the square of the fault quantity
- It makes possible to use short time delay in spite of high switching in current
- Used when fault quantity is dependent on fault location
- Suitable for protection of feeders, with peak current on switching (refrigerators, pumps water heaters etc) and also for alternator transformers and expensive cables.

### Long time inverse characteristics

This characteristics is used as back up earth fault protection as the time inversely proportional to the intensity of fault quantity.

### Over voltage and under voltage relays

This electromagnetic relays are working on the same principle of induction type disc type relays. The sensor used in this relay input is from PT (potential transformer) where output generally kept on 110v AC.

When the fault occurs the PT output produces a voltage which in turn energise the disc mechanism to rotate. As the fault continue to represent; and the trip time settled, the relay disc rotates and make the trip coil to activate in the trip mechanism in the breakers. The tripping time settled as per the characteristics selected. The pick up voltage has to be verified with the plug setting value of fault voltage which can be selected in different fault voltages in both over/ under voltage relay. Time Multiplier Setting (TMS) shorten the trip time if necessary on the fault quantity is more as the case may be.

## Time multiplier setting

This setting helps the relay to shorten the time selected without change of any other settings made in the relay. Time multiplier helps the relay to activate fast the breaker in case the fault quantity is more than 50% of the fault quantity selected by the tap setting.

## Differential protection relay

Differential protection is a very reliable method of protecting generators, transformers, busbar and transmission lines from the effects of internal faults. In normal operating conditions the current through the CTs is the same. So the relay sense no differential current. This is also the case for external faults. Differential protection can be used for protecting generators from faults to ground. Differential protection of busbars in substations uses one CT for each incoming line. All incoming currents are added up and compared to the sum of all out going currents.

General schematic diagram of differential protection relay is in Fig 7.

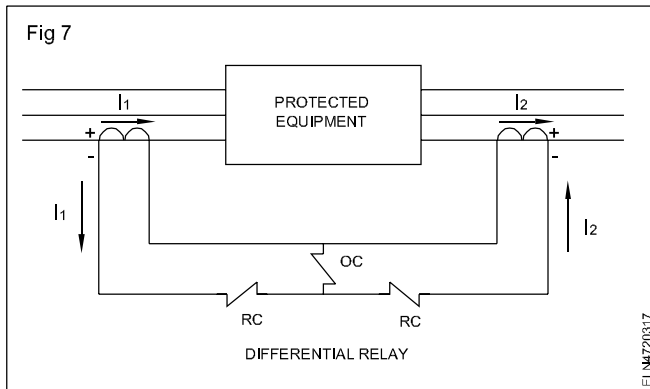

The installation of differential relay for protection of power transformers used in transmission line is in Fig 8.

## Distance relays / Admittance relay

The impedance of a transmission line is proportional to its length, for distance measurement it is appropriate to use a relay capable of measuring the impedance of a line up

to a predetermined point (the reach point) Such a relay is described as a distance relay and is designed to operate only for faults occurring between the relay location and the selected reach point thus giving discrimination for faults that may occur in different line sections

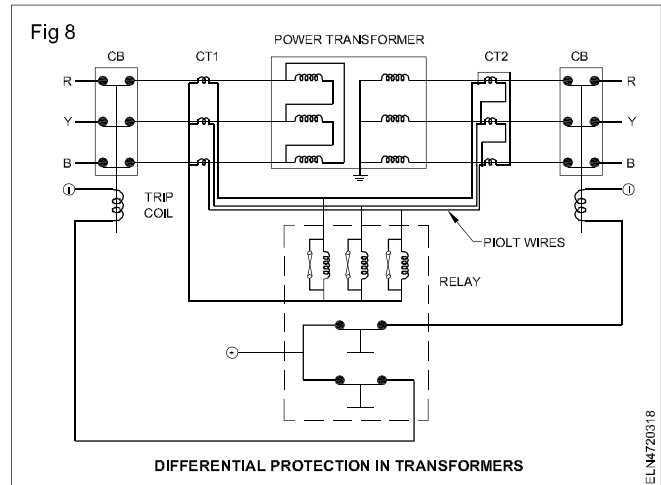

## Reactance relays (or) Shaded pole type non directional relay

The reactance relay is a straight line characteristic that responds only to the reactance ( $X_L$ ) of the protected line. It is non directional and is used to supplement the admittance relay as a tripping relay to make the overall protection independent of resistance. It is particularly useful on short lines where the fault arc resistance is the same order of magnitude as the line length.

The relay serves an important part in switchgear protection. The electromagnetic relay is the first generation of protective relays and it has many moving parts and working in the principles of induction. Electromagnetic relay can carry one function i.e., over current, over voltage or under voltage at a time. This drawback is overcome by the use of static or digital relay which can use for multi function, as well as more accurate than electromagnetic relays.



**Circuit breakers - parts - functions- tripping mechanism**

**Objectives:** At the end of this lesson you shall be able to

- state about circuit breaker
- list the various types of circuit breakers
- explain the parts of each circuit breakers
- explain the principle of operation of circuit breaker
- explain the application and uses of circuit breaker.

**Circuit breaker**

Circuit breakers are the electrical device (or) equipment, which makes or breaks the electrical circuit. In a 240 volt single phase system a low rated single pole switch can use the circuit to break or make. But in this case the resultant spark at the contacts are negligible and this will not make any fire, in the circuit or contacts since the current is very low.

But in the case of heavy loads; say some hundreds, of ampere are flowing in a circuit the resultant spark at contact are heavy and this leads to electrical fire. To overcome this problem the sparks at the contacts are to be controlled or quenched, when any load makes or breaks. The equipment or device used to make or break a circuit under control at the same time it prevents or quenching the resultant fire is called as a circuit breaker. The breakers are named after the quenching medium used to control the fire such (1) air circuit breaker, (2) oil circuit breaker, (3) vaccum circuit breaker and (4) Sulphur hexafluoride (SF<sub>6</sub>) circuit breaker.

**Air circuit breaker (ACB)**

A circuit breaker which uses the either natural air or blast air as an Arc quenching medium is termed as Air-circuit breakers.

ACB is widely used upto 15KV in place of oil circuit breaker because there is no chance of the fire due to the quenching oil as in case of OCB.

Air- Circuit breakers are widely used in industries as well as power system for controlling and protection of different section of the circuit like, Transformers, Motors, Generators / Alternator etc and leads the system stable and reliable. Other components are also associated with circuit breakers like fuses, relays, switches etc.

**Construction of air - circuit breaker**

External lables / parts of ACB in Fig.1

- 1 OFF button (O)
- 2 ON button (I)
- 3 Main contact position indicator
- 4 Energy storage mechanism status indicator

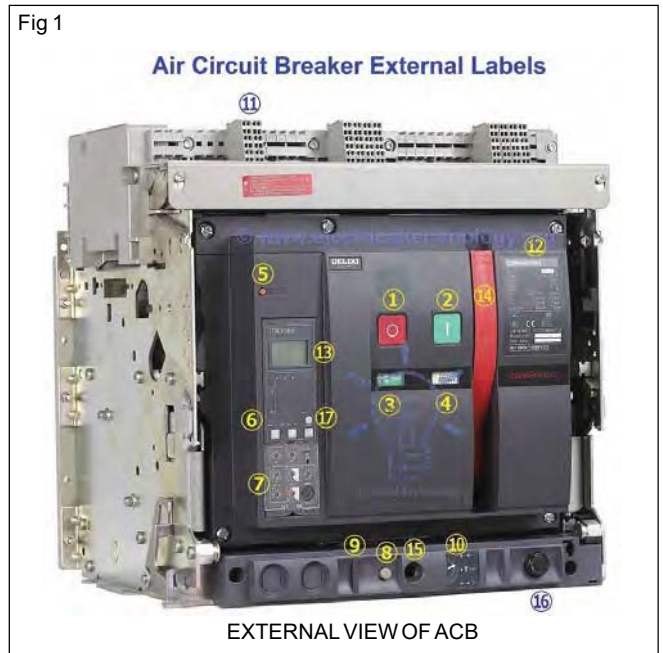

- 5 Reset button
- 6 LED indicators
- 7 Controller
- 8 "Connection" "Test" and "isolated" position latching / locking mechanism
- 9 User padlock
- 10 Connection, "Test", and isolated position indication
- 11 Connection test and isolated position indication contacts
- 12 Name plate
- 13 Digital displays
- 14 Energy storage handle
- 15 Draw out /in hole
- 16 Rocker repository
- 17 Trip reset button

**Internal construction of air circuit breaker**

The internal parts of an ACB in Fig.2

- 1 Sheet steel supporting structure
- 2 Current transformer for protection trip unit

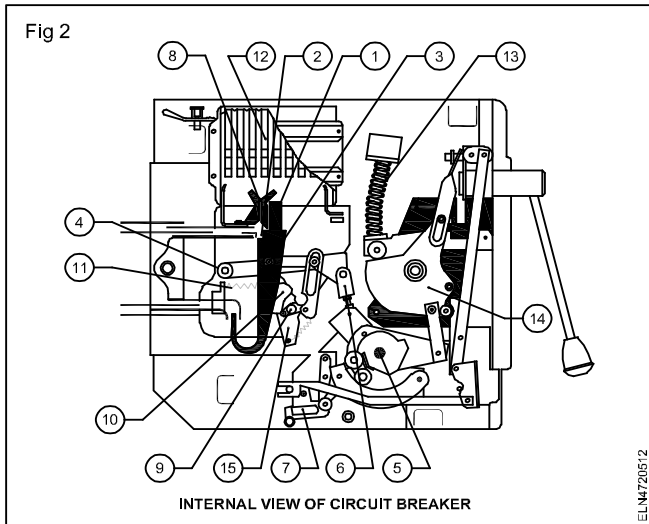

- 3 Pole group insulating box
- 4 Horizontal rare terminals
- 5 Plate for fixed main contacts
- 6 Plates for fixed arcing contacts
- 7 Plate for main moving contacts
- 8 Plates for moving arcing contacts
- 9 Arcing chamber
- 10 Terminal box for fixed version - sliding contacts for withdrawable version
- 11 Protection trip unit
- 12 Circuit breaker closing and opening control
- 13 Closing springs
- 14 Spring loading arrangement
- 15 Manual releasing lever

### Principle of operation of air circuit breaker

- When the circuit breaker opens the circuit either under the normal condition or in the fault condition, some Arc is produced between the main contacts and some current flows to the load, called **transition current** through the arc.
- This Arc and the current should be suppressed / eliminated especially during the fault condition otherwise the severity of the fault level will be more and damages the circuit which leads to the electric fire.
- During the period of Arc some voltage appears across the main contacts called **transition voltage**, which will be more than the rated system / supply voltage.
- To quench the Arc, this transition voltage should be reduced or the Arc voltage to be increased. The minimum voltage required to maintain the arc is called as **Arc voltage**. In ACB, the Arc voltage is increased in the following three ways.
- Arc voltage can be increased by cooling arc plasma by air. The temperature of arc plasma is reduced, more voltage will be required to maintain the arc.

- By splitting the arc into a number of series in Arc chute will increase the arc voltage.
- Arc voltage can be increased by lengthening the arc path. As length of arc path is increased its resistance of the arc path will increase hence the arc voltage is increased.

Some ACB contains two pairs of contact. The main pair carries the current and is made of copper. An additional pair of contact (Arc contact) is made of carbon. When the breaker is opened, the main contact opens first and the arc contact remains in touch. The arcing gets initiated when arc contacts are separated.

Hence transition voltage will be reduced.

### Application and uses of air circuit breaker

- It is used for protection of plants
- It is used for common protection of electrical machines
- Air circuit breaker is also used in electricity sharing system up to 15KV
- Also used in low as well as high voltage and current applications.
- It is used for protection of transformers, capacitors and generators.

### Types of air circuit breaker

- Plain air circuit breaker
- Air blast circuit breaker

### Plain air circuit breaker

In this circuit breaker a chamber is fitted surrounding the contact. The chamber is known as "**arc chute**". The arc chute will help in achieving cooling. Arc chute is made from some refractory material.

The arc chute is divided into a number of small compartments by using metallic separation plates called **arc splitters** and behave as a mini arc chute as in Fig.3. Initial arc will split into a series of arcs and make the arc voltages higher than system voltage. They are preferable choice in low voltage application.

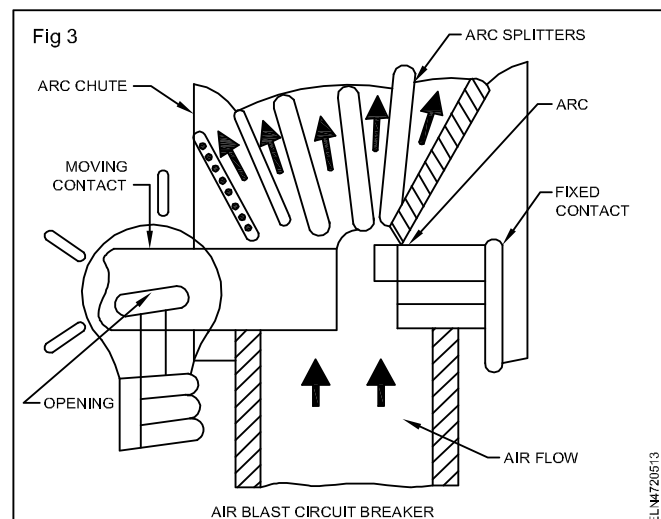

## Air blast circuit breaker

ACB which uses the high pressure (blast) air as an Arc quenching medium is known as Air-Blast- Circuit-Breaker(ABCB).

This type of circuit breaker is used for high voltage application and can be further divided into three categories.

- Axial blast air circuit breaker
- Cross blast air circuit breaker
- Radial blast air circuit breaker

### Advantages of air - blast circuit breaker

- Air blast circuit breaker is used where the frequent operation is required because of lesser arc energy.
- The risk of fire due to oil is eliminated in the air blast circuit breaker
- Arc quenching is much faster
- Air blast circuit breaker is small in size, because of the fast Arc quenching.
- The duration of the arc is same for all the values of current.
- Operating speed of circuit breaker is much higher.
- Stability of operation is high because of speed of operation.
- It requires less maintenance

### Disadvantages of air -blast circuit breaker

- Additional air supply plant requires hence require additional maintenance.
- It require high capacity air compressor.
- There is a chance of air pressure leakage.
- There is chance of a high rate of re - striking voltage and current chopping.
- The air has relatively lower arc extinguishing properties than oil.

## Oil circuit breakers (OCB)

Circuit breakers which uses the insulating oil (e.g transformer oil ) as an arc quenching medium is called as oil circuit breaker. The main contacts of the OCB are opened under the oil and an arc is struck between them. The heat of the arc evaporates the surrounding oil and dissociates it into gaseous of hydrogen at high pressure.

The hydrogen gas occupies a volume about one thousand times that of the oil decomposed. The oil is, therefore, pushed away from the arc and an expanding hydrogen gas bubble surrounds the arc region of the contacts. The arc extinction is completed by two processes. Firstly, the hydrogen gas has high heat conductivity and cools the arc, thus aiding the de-ionization of the medium between the contacts.

Secondly, the gas sets up turbulence in the oil and forces it into the space between contacts, thus eliminating the arc as in Fig 4. The result is that arc is extinguished and circuit current is interrupted.

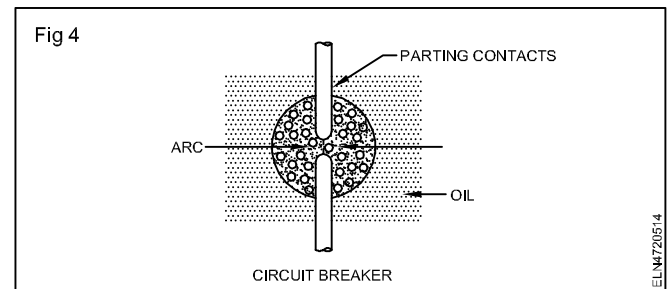

### The advantages of oil as an arc quenching medium

- i It absorbs the arc energy to decompose the oil into gases which have excellent cooling properties.
- ii It acts as an insulator and permits smaller clearance between main contacts.
- iii The surrounding oil presents the cooling surface in close proximity to the arc.

### The disadvantages of oil as an arc quenching medium.

- i It is inflammable and there is a risk of a fire.
- ii It may form an explosive mixture with air.
- iii The arcing products (e.g. carbon) remain in the oil and it deteriorates the quality of insulating oil.
- iv Periodic checking and replacement of the insulating oil is required.

### Types of oil circuit breakers

- a) Plain break oil circuit breakers
  - b) Arc control oil circuit breakers.
- ii Low oil circuit breakers

### Plain break oil circuit breakers

In plain- break oil circuit breaker the main contacts are placed under the whole oil in the tank. There is no special system for arc control other than the increase in length of separation of the contacts. The arc extinction occurs when a critical gas is reached between the contacts.

The plain - break oil circuit breaker is the oldest type and has a very simple construction. It consists of fixed and moving contacts enclosed in a strong weather- tight earthed tank containing transformer oil upto a certain level and an air cushion above the oil level.

The air cushion provides sufficient room to arc gases without the generation of unsafe pressure in the circuit breaker. It also absorbs the upward oil movement. Fig 5 shows a double break plain oil circuit breaker. It is called a double break because it provides two breaks in series.



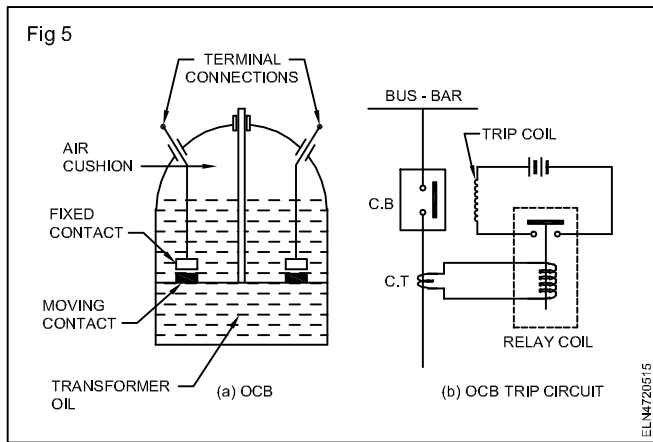

### Principle of working

Under normal operating conditions, the fixed and moving contacts remain closed and carries the normal circuit current. When a fault occurs, the moving contacts are pulled down by the tripping mechanism and an arc is produced which vaporizes the oil into hydrogen gas. The arc extinction is completed by the following processes.

- i The hydrogen gas bubble generated around the arc, cools the arc.
- ii The gas sets up turbulence in the oil and helps in eliminating the arc.
- iii As the arc lengthens due to the separation of contacts, the Arc voltage is increased.

The result is at some critical gap, the arc is extinguished and the circuit current is interrupted.

### Disadvantages

- i There is no special control over the arc other than the increase in gap length.
- ii These breakers have long and inconsistent arcing times.
- iii The speed of interruption is less.

Due to these disadvantages, plain - break oil circuit breakers are used only for low - voltage not exceeding 11 KV applications where high breaking- capacities are not important.

### Arc control oil circuit breakers

In plain-break oil circuit breaker there is very little artificial control over the arc. Therefore long arc length is essential in order to quench the Arc. If some arc control is incorporated at still short contact gap than the breakers are called arc control oil circuit breakers.

They are two types

- a Self - blast OCB
- b Forced - blast OCB

### Low oil circuit breakers

In the bulk oil circuit breaker, only a small percentage of oil (about 10% of total) is actually used for arc extinction. But the huge volume of oil used in bulk oil circuit breaker increases the expenses, tank size, weight of the breaker, increases the fire risk and maintenance problems.

To overcome the above disadvantages the low oil circuit breaker is developed which employs solid materials for insulation purposes and uses a small quantity of oil which is just sufficient for quenching the arc. By using suitable arc control devices, the arc extinction can be further simplified in a low oil circuit breaker.

**Construction :** Fig 6 shows the single phase low oil circuit breaker. There are two compartments separated from each other and filled with oil. The upper chamber is the **circuit breaking chamber** whereas the lower one is the **supporting chamber**. The two chambers are separated and the oil from one chamber is prevented from mixing with the other chamber.

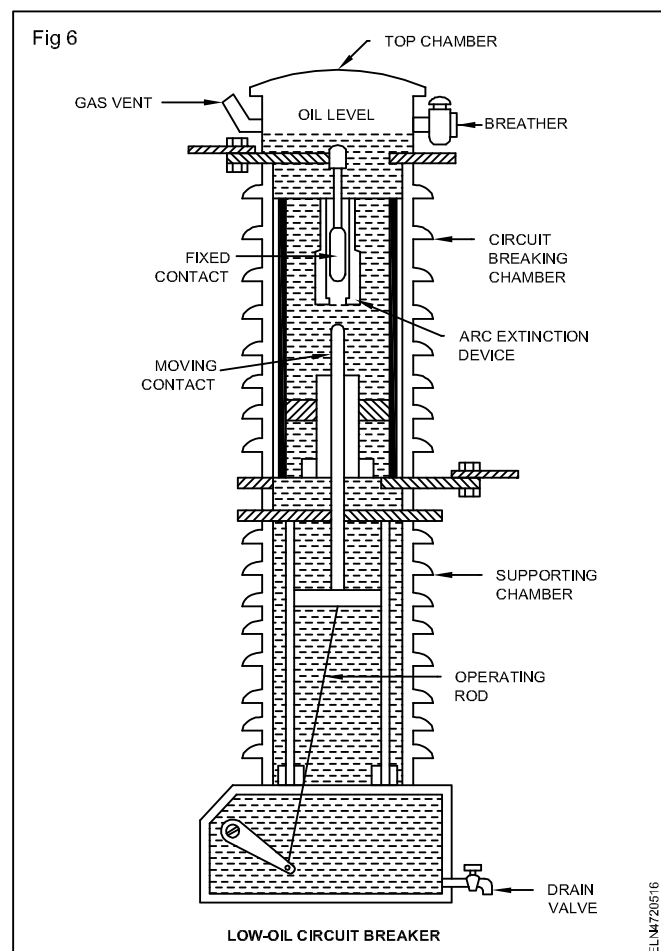

This arrangement has three advantages.

- 1 The circuit breaking chamber requires a small volume of oil which is enough for arc extinction.
- 2 The amount of oil to be replaced is considerably reduced
- 3 The oil in the supporting chamber does not get contaminated by the arc.

- i **Supporting chamber** : It is a porcelain chamber filled with oil which is physically separated from the oil in the circuit breaking compartment. The oil inside the supporting chamber and porcelain insulation is employed for insulation purposes only.
- ii **Circuit breaking chamber** : It is a porcelain enclosure mounted on the top of the supporting chamber and filled with oil and has the following parts.
  - a) Fixed contacts
  - b) Moving contacts
  - c) Turbulator

The moving contact enters top chamber through a fixed piston. The turbulator is an arc control device and has both axial and radial vents. The axial vent for low currents whereas radial vent for heavy currents rating breakers.

- iii **Top chamber** : It is a metal chamber mounted on top of the circuit - breaking chamber. It provides space for the oil expansion in the circuit breaking chamber. The top chamber also has a gas vent pipe and breather through which the escaping gas and entering air may pass through to the circuit breaking chamber during the breaking of fault current.

**Operation** : Under normal operating conditions, the moving contact engages with the fixed contact. When a fault occurs, the moving contact is pulled down by the tripping mechanism and an arc is produced. The arc vaporizes the oil and produces gas to escape through the gas vent.

This action results the oil to pass through a central hole of the moving contact and forcing the oil through the respective vents of the turbulator. The arc are successively quenched by the effect of streams of oil passes through the vent while gas passes.

**Advantages** : A low oil circuit breaker has the following advantages over a bulk oil circuit breaker.

- i It requires lesser quantity of oil
- ii Cost of the breaker is less
- iii It requires smaller space
- iv The weight of the breaker is less
- iv There is reduced risk of fire
- vi Maintenance problems and cost are reduced

**Disadvantages** : A low oil circuit breaker has the following disadvantages as compared to a bulk oil circuit breaker

- i There is a difficulty of removing the gases from the contact space.
- ii Due to smaller quantity of oil, the effect of carbonization is increased.
- iii The dielectric strength of the oil deteriorates fastly due to high degree of carbonization.

## Vacuum circuit breaker (VCB)

Circuit breaker which uses vacuum as an arc quenching medium is called as vacuum circuit breaker.

Vacuum offers the highest insulating strength and have the superior arc quenching properties than any other medium. When the contacts of a breaker are opened in vacuum, the interruption occurs instantly as the dielectric strength between the contacts are many times higher than the other circuit breakers.

The technology is only suitable for medium voltage application. For higher voltage application, the vacuum technology has been developed.

### Principle of vacuum circuit breaker

- When the contacts of the breaker are opened in vacuum ( $10^7$  to  $10^5$  torr), an arc is produced between the contacts by the ionisation of metal vapours i.e, combination of electrons and ions of contacts. However, the arc is quickly extinguished because the metallic vapours, rapidly cools resulting quick recovery of dielectric strength.
- The salient feature of vacuum is, as soon as the arc is produced in vacuum, it is quickly extinguished due to the rapid recovery of dielectric strength of vacuum.

### Construction of vacuum circuit breaker

Fig 7 shows the typical parts of vacuum circuit breaker

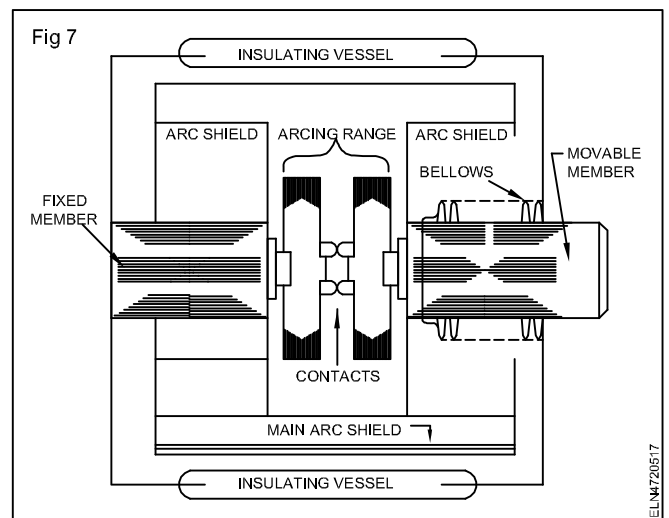

- It consists of the fixed contact, moving contact and arc shield mounted inside a vacuum chamber.
- The movable member is sealed by a stainless steel bellows, is connected to the control mechanism . This enables the permanent sealing of the vacuum chamber, to eliminate the possibility of leak.
- A glass vessel or ceramic vessel is used as the outer insulating body.
- The arc shield prevents the metallic vapours falling on the inside surface of the outer insulating cover.

## Working of vacuum circuit breaker

- When the breaker opens, the moving contact is separated from the fixed contact and an arc is produced between the contacts. The production of arc is due to the ionisation of metal ions and depends upon the material of contacts.
- The arc is quickly extinguished because the metallic vapours, are diffused in a short time and condensed on the surfaces of moving and fixed members and arc shields.
- Since vacuum has rapid Arc recovery rate of dielectric strength, the arc extinction in a vacuum breaker occurs with a short separation (say 0.625 cm) of contacts.

## Application of VCB

- Vacuum circuit breakers are employed for outdoor applications ranging from 22KV to 66KV.
- They are suitable for majority of applications in rural areas.

## Sulphur hexafluoride (SF<sub>6</sub>) circuit breaker

Circuit breakers which uses the sulphur hexafluoride gas (SF<sub>6</sub>) as an arc quenching medium is called as SF<sub>6</sub> circuit breaker.

The sulphur hexafluoride gas (SF<sub>6</sub>) is an electronegative gas and has a strong tendency to absorb the free electrons. When the contacts of the breaker are opened in a high pressure sulphur hexafluoride (SF<sub>6</sub>) gas medium and an arc is struck between them.

The SF<sub>6</sub> gas capture the conducting free electrons in the arc and form immovable negative ions. This loss of conducting electrons in the arc quickly improve the insulation strength to extinguish the arc.

The sulphur hexafluoride (SF<sub>6</sub>) circuit breakers are very effective for high power and high voltage applications.

## Construction of SF<sub>6</sub> circuit breaker

A sulphur hexafluoride (SF<sub>6</sub>) circuit breaker consists of fixed and moving contacts enclosed in a chamber as in Fig 8. The chamber is called arc interruption chamber which contains the sulphur hexafluoride (SF<sub>6</sub>) gas and it is connected to sulphur hexafluoride (SF<sub>6</sub>) gas reservoir.

When the contacts of breaker are opened, the valve mechanism permits a high pressure sulphur hexafluoride (SF<sub>6</sub>) gas from the reservoir to flow towards the arc interruption chamber.

The fixed contact is a hollow cylindrical contact fitted with an arc horn. The moving contact is also a hollow cylinder with rectangular holes in the sides. The holes permit the sulphur hexafluoride gas (SF<sub>6</sub>) to let out through them after flowing along and across the arc.

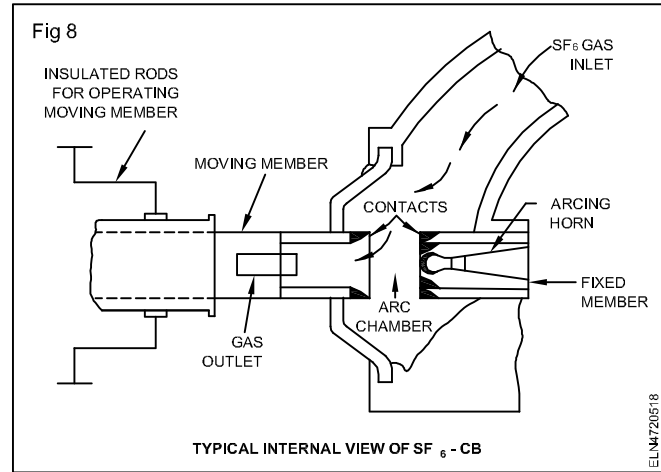

The tips of fixed contact, moving contact and arcing horn are coated with copper - tungsten arc resistant material. Since sulphur hexafluoride gas is costly, it is reconditioned and reclaimed using suitable auxiliary system after each operation of breaker.

## Working of SF<sub>6</sub> circuit breaker

In the closed position of the breaker, the contacts remain surrounded by SF<sub>6</sub> gas at a pressure of about 2.8 kg/cm<sup>2</sup>. When the breaker opens, the moving contact is pulled apart and an arc is struck between the contacts. The movement of the moving contact is synchronized with the opening of a valve which permits SF<sub>6</sub> gas at 14kg /cm<sup>2</sup> pressure from the reservoir to the arc interruption chamber.

The high pressure flow of SF<sub>6</sub> gas rapidly absorbs the free electrons in the arc path to form immovable negative ions which are ineffective as charge carriers. The result is that the medium between the contacts rapidly improve the dielectric strength and causes the extinction of the arc. After the breaker operation (i.e. after arc extinction), the valve mechanism is closed by a set of springs.

## Advantage of SF<sub>6</sub> circuit breaker

Due to the superior arc quenching properties of SF<sub>6</sub> gas, the sulphur hexafluoride gas circuit breakers have many advantages over oil or air circuit breakers. Some of them are listed below.

- 1 Such circuit breakers have very short arcing time.
- 2 Since the dielectric strength of SF<sub>6</sub> gas is 2 to 3 times more than the air, such breakers can interrupt much larger currents.
- 3 SF<sub>6</sub> circuit breaker gives noiseless operation due to its closed gas circuit and no exhaust to the atmosphere unlike the air blast circuit breaker.

# Tripping mechanism of circuit breakers

**Objectives:** At the end of this lesson you shall be able to

- State the necessity of tripping mechanism
- state the types of tripping mechanism.

## Tripping mechanism of circuit breakers

**Trip mechanism :** Trip mechanism is incorporated in the circuit breaker to switch off the circuit breaker at faulty condition either automatically or manually at the desired time.

Fig 1 shows the arrangement. When the circuit breaker is closed, the mechanism is locked in position by a system of linkages. This lock can be released by lifting the trip bar.

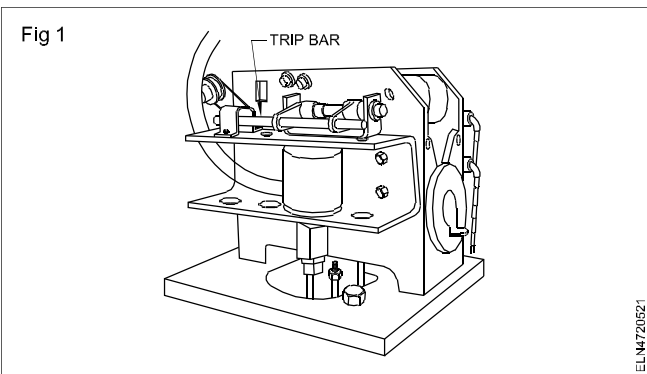

Trip bar is attached to the tripping lever which in turn can be operated manually. The tripping lever is generally kept locked. When the trip bar is lifted the mechanism opens the breaker contacts.

**Trip coils:** When remote operation is desired, trip coils are used. The trip coils are small solenoids either operated by AC or DC supplies. Fig 2 shows the general arrangement of the trip coil mechanism. A plunger moves freely inside the solenoid. When the solenoid is energised by the trip switch the plunger moves up and release the lock which holds the trip bar. Further the trip coils are also actuated by short circuit /overload and under -voltage relays as described in the following paragraphs.

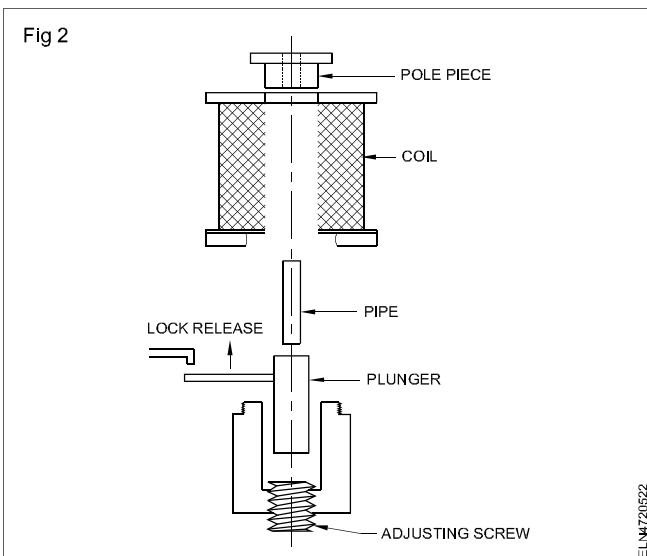

**Shunt trip coils :** The shunt trip coil requires an auxiliary supply, a C.T and a relay. The relay can be set to give time-graded protection. The relay closes the trip coil circuit when the load current exceeds the stipulated value. This relay is in Fig 3.

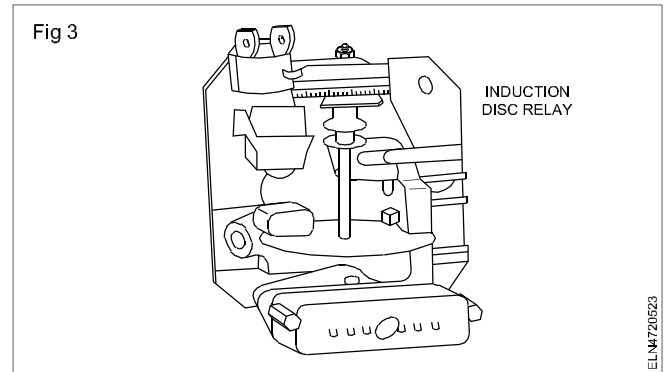

**Series trip coil:** The series trip coil mechanism in Fig 4 consists of a series solenoid with a plunger controlled by a spring. When current in the load become excessive the plunger rises and trips the mechanism.

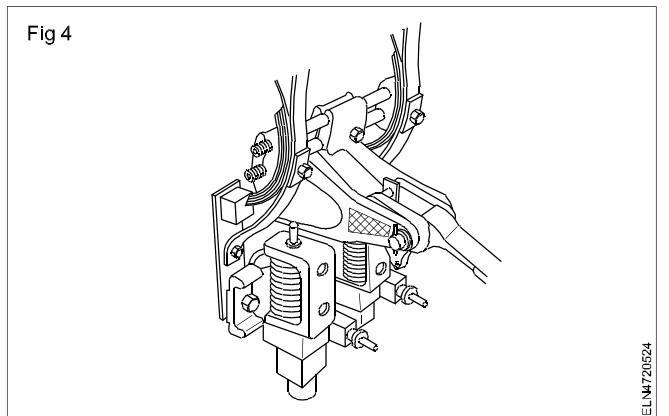

The current necessary to trip the circuit breaker is regulated by a screw which adjusts the tension of the spring controlling the plunger. Time-lag can be adjusted by the position of the dash pot which holds the piston of the plunger in the oil bath.

In three-phase circuit breakers, there are three series trip coils, three dash pots, three plungers. They can operate the trip mechanism together or independently.

**Under voltage release coils :** The under-voltage release coil is used in installations where detection and isolation of abnormally low voltage is required. The construction of the under-voltage trip coil in Fig 5 is similar to the trip coils discussed above except that the plunger is held away from the pole piece by a coiled spring. Under normal operating conditions, the solenoid is energised and the plunger is held down against the force of the spring. When

the supply voltage falls, the under - voltage release coil will not be in a position to hold the plunger down against the spring tension. Thus the plunger moves up and pushes the trip bar to the circuit breaker.

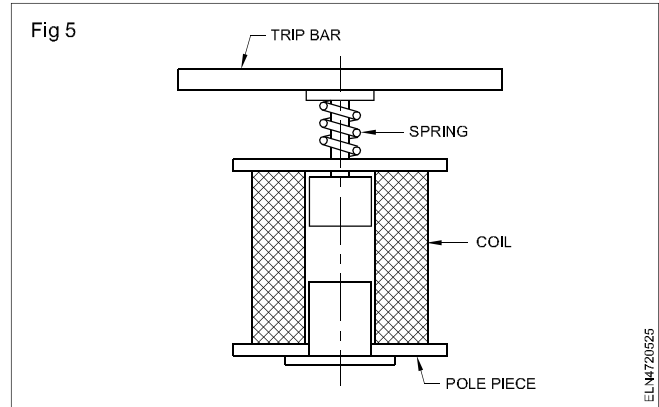



**Repair and maintenance of CBs**

**Objectives:** At the end of this lesson you shall be able to

- explain the procedure to carry out maintenance and repair of a OCB
- state the method to adopt checking and maintenance/repair of ACB & VCB
- explain the procedure of the condition of SF<sub>6</sub> circuit breakers and their repair and maintenance.

Any circuit breaker has the fundamental operation is to make and break the circuit. The design and operating procedure depends on the breaking/making load current in the circuit. Selection of quenching medium (oil, air, vacuum or gas) and the volume is involved main factors and proper maintenance is very important to keep the breaker accurate performance and long life.

**Maintenance & repair of oil breaker**

It is the first generation of circuit breaker used in the electrical protection circuit and it is still in use. High insulated oil is the main quenching medium and the oil storage maintenance is quite difficult. Frequent purification, reconditioning, refilling and leak proof storage etc. keeps the breaker always healthy. Due to this oil storage, recondition and refilling problem, oil circuit breakers are replaced by modern vacuum circuit breaker. Troubleshooting chart at this end will help to carryout smooth maintenance and repair of OCB.

**Maintenance & repair of ACB, & VCB**

Air circuit breaker are found in variety of applications such as very low, low, medium and high current applications. Natural air with arc chutes in chamber found useful in very low and low to medium circuit breaker. Very high voltage to EHT lines the VCB are used very extensively.

Natural air or forced air used for ACBs arc chutes are common in both ACB chamber, but in high voltage ACB forced or compressed air blow is used. To produce compressed air, air chamber, air compressor is necessary in order to operate ACB.

Maintenance is also required at fixed and moving contacts of OCB. Alloy metals are used to make the tips of contacts part in conductors. But in usage these contacts are partially melted or damaged or repaired frequently otherwise quenching time will increase rapidly.

The tension of loading springs and manual operating levers are to be checked and rectified if any mechanical part is found defective. The coils, electromagnets and other electrical parts are to be checked for its effectiveness. A comprehensive service flow chart is attached for detailed repair and maintenance.

**Maintenance & repair of SF<sub>6</sub> circuit breaker**

It is a advanced version and compact to use mainly for indoor substation. Since the SF<sub>6</sub> gas is poisonous proper protective gadgets are to be used while handling SF<sub>6</sub> circuit breaker.

The loading, tripping mechanism almost same as that of VCB and air blast ACB. The maintenance and repair mentioned may have to follow in this case also.

The main maintenance requirement in SF<sub>6</sub> circuit breaker are handling gas or charging gas. No recondition is possible the SF<sub>6</sub> total replacement is required in case of any gas failure. More cycle of operation will cause the reduction of gas strength and reducing gas pressure also will be the reason of SF<sub>6</sub> circuit breaker failure.

The SF<sub>6</sub> chart illustrate the relevant failure/repair of the circuit breaker.

**Troubleshooting chart - 1**

S.No	Type of fault	Cause	Effects/remedy
1	Excessive heat in oil	- Poor dielectric strength	- Heavy spark inside the tank in long duration - Change the oil
2	Oil level diminishing fast	- Leak in tank	- Arrest the leak
3	Sledge deposit in bottom of tank	- Adulterated oil, very old oil filled	- No proper contacts in the bottom of tank - Filter the oil

S.No	Type of fault	Cause	Effects/remedy
4	Spark continuing in the electrode contact after making circuit	<ul style="list-style-type: none"> <li>- Conductor tip damaged</li> <li>- No proper contact</li> <li>- Pressure spring defect</li> </ul>	<ul style="list-style-type: none"> <li>- Increased oil temperature</li> <li>- Leads to breakage of the tank</li> <li>- Rectify spring (or) contact tip</li> </ul>
5	Manual breaking not functioning	<ul style="list-style-type: none"> <li>- Loading spring defect</li> <li>- Loading mechanism defective</li> </ul>	<ul style="list-style-type: none"> <li>- No breaking is possible</li> <li>- Rectify</li> </ul>
6	No tripping in fault condition	<ul style="list-style-type: none"> <li>- Defective tripping mechanism</li> <li>- Defective tripping coil</li> </ul>	<ul style="list-style-type: none"> <li>- Fault condition will continue</li> <li>- Damage the machine connected in line</li> </ul>
7	Very loud noise in ACB while operation	<ul style="list-style-type: none"> <li>- Insufficient air flow air pressure in chamber</li> </ul>	<ul style="list-style-type: none"> <li>- Continuous vibration once it is operated.</li> <li>- Maintain air pressure</li> </ul>
8	Moving contact broken	<ul style="list-style-type: none"> <li>- Excessive heat</li> <li>- Excess spring tension</li> <li>- Miss alignment</li> </ul>	<ul style="list-style-type: none"> <li>- Moving contact fail to make contact with fixed contact</li> <li>- Change the contact</li> </ul>
9	Melting of electrode tip	<ul style="list-style-type: none"> <li>- Excessive current produces heavy spark</li> <li>- Substandard alloy metal</li> <li>- Arc quenching is extended beyond the set values</li> </ul>	<ul style="list-style-type: none"> <li>- Check the source of excessive current</li> <li>- Use standard alloy metal</li> <li>- Maintain arc quenching medium in good condition</li> </ul>
10	Intermittent tripping of breaker	<ul style="list-style-type: none"> <li>- Wrong setting in relay</li> <li>- Defective or faulty loading spring</li> <li>- Faulty moving mechanism</li> </ul>	<ul style="list-style-type: none"> <li>- Correct the setting</li> <li>- Repair spring and loading mechanism</li> </ul>
11	Shock in the breaker	<ul style="list-style-type: none"> <li>- Earth fault</li> </ul>	<ul style="list-style-type: none"> <li>- Do proper earth connection</li> </ul>