

Timing Gear Drive

Objective: At the end of this lesson you shall be able to

- state the timing gear drive.

- Timing Gear drive
- Timing Chain drive

Timing Gear drive

This direct drive (Fig 1) is used where the crankshaft and the camshaft are very close to each other. Since the r.p.m. of the camshaft is half of the crankshaft speed, the camshaft gear (1) teeth is twice as many as the crankshaft gear (2) teeth. In this, the engine's camshaft rotates in the reverse direction of the crankshaft. In some engines an idler gear is used to have the same direction of rotation for the crankshaft and the camshaft. When camshaft and crankshaft is assembled after overhauling the engine the timing marks should be coincides as in Fig 1.

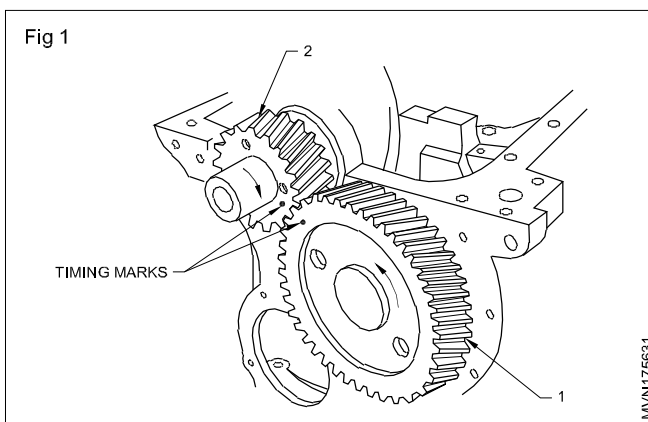

Timing chain (Fig 2)

With this type of sprocket drive the camshaft is driven by means of a chain with the aid of various.

Auxiliary components

Single or multiple chains are used in this type of drive.

The chain is usually tensioned by means of a hydraulic chain tensioner which is controlled by the engine oil pressure.

Clutch

Objectives: At the end of this lesson you shall be able to

- state the need for a clutch
- list out different types of clutch
- state the function of the clutch
- state the construction of fluid coupling

Need for a clutch

Depending upon the different loads are requiring change of speed to match the rated power available in the engine. Vehicle speed can be changed by shifting gears.

While shifting gears, the speed of the sliding sleeve and the respective gear on the main shaft should be synchronised to avoid gear collision noise. This is achieved by disconnecting the transmission of power from the engine flywheel to the gear box shaft with the help of the clutch. Thus,

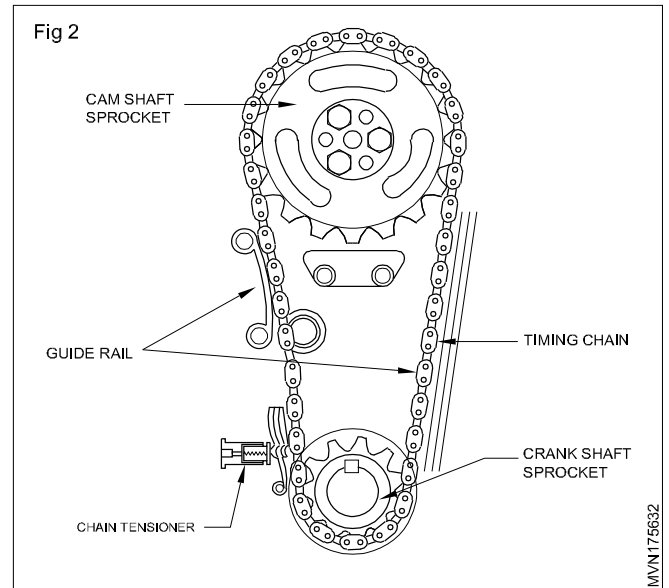

The chain is additionally guided in rails to the chain vibration and noise.

The direction of crank shaft and camshaft is same.

The chain and chain tensioner are only subject to minimal wear so that servicing is unnecessary. If need be, i.e. in the event of excessive wear, the chain must be renewed. If a fault is found the chain tensioner is changed.

- 1 Camshaft sprocket
- 2 Timing chain
- 3 Crankshaft sprocket
- 4 Chain tensioner
- 5 Guide rail

clutch is used to connect and disconnect transmission of power from the engine flywheel to the gear box drive shaft.

Function of the clutch

- The clutch should connect the power from the engine to transmission smoothly gradually without affecting the other components.
- It should damp vibrations and shocks during operation.
- It should not slip under high torque transmission.

Torque transmission by clutch depends upon the:

- contact area of the clutch plate.
- co-efficient of friction of lining material.
- spring pressure.
- number of clutch plate used.

Different type of clutches

They are

- Single plate clutch
- Multi - plate clutch
- Dual clutch
- Dry and wet clutches
- Cone clutch
- Dog clutch
- Diaphragm spring type clutch
- Fluid coupling

Single plate clutch (Fig 1): A clutch consists of driven (1) and driving shafts (2). A clutch cover (3) is mounted on the flywheel (4) by a set of screws (5). A pressure plate (6) presses the clutch plate (7) against the flywheel by the pressure of springs (8). The clutch plate hub (9) is splined (10) on the gear box drive shaft. The clutch plate rotates along with flywheel and power is transmitted to the drive shaft. When the clutch pedal is pressed, the release bearing (11) pushes the thrust plate (12) through the linkages.

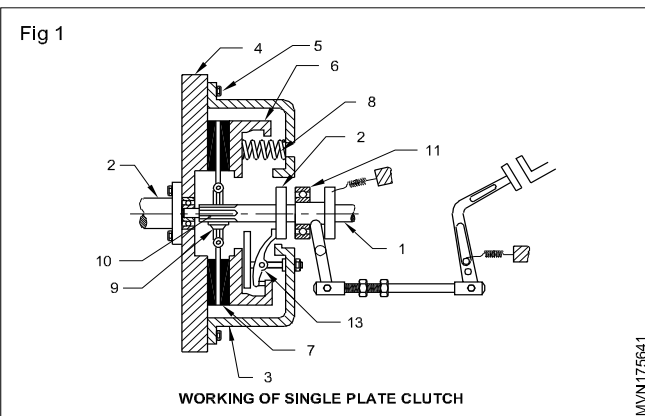

The thrust plate pushes the clutch finger (13), the clutch finger swivels and moves the pressure plate away from the flywheel. When the springs are compressed, the pressure plate does not exert pressure on the clutch plate and in turn the clutch plate does not transmit power from the flywheel to the drive shaft.

The clutch plate (Fig 2) consists of a torque plate (14) and clutch lining (15) made of frictional material fixed on the torque plate by reverts (16). Damper spring (17) are fixed in the torque plate to dampen shocks and vibrations during clutch operation.

Multi-plate clutch (Fig 3)

To transmit more torque, more contact area is necessary. Instead of using a larger diameter clutch plate, two or three small clutch discs are used to increase in frictional area. The pressure plates (2) and clutch plates (1) are alternatively arranged on the clutch shaft (3) and compressed by a number of pressure springs (4). This type works in the same way as a single plate clutch does.

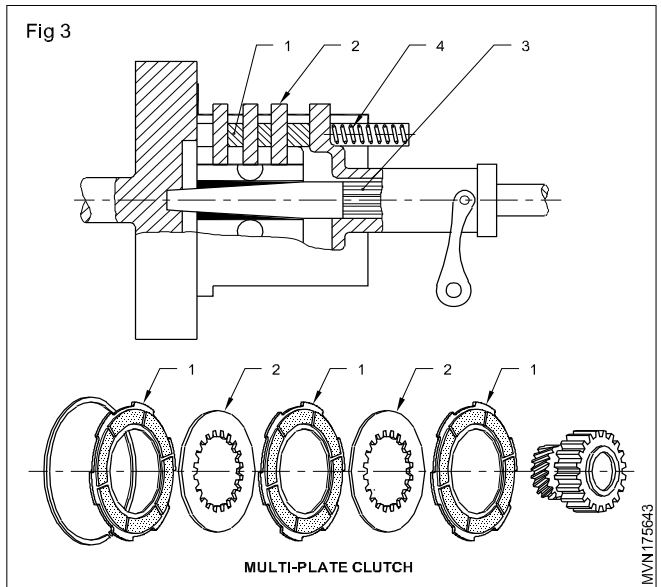
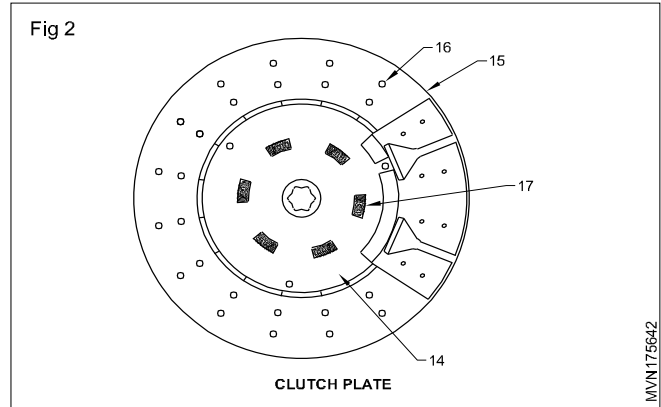

Dual clutch (Fig 4)

Dual clutches are combination of the primary master clutch (1) transmitting torque to the driving wheel and secondary P.T.O clutch (2) to drive P.T.O shaft. Dual clutch is mounted into the flywheel with primary pressure ring plate (3) and PTO pressure ring plate (4) (Fig.4) Disc spring (5), inserted in between two pressure rings, through insulating pad (6), pressing on both plates with there outer friction surface is the pressure element. Clutch guard (7) is mounted on the flywheel for safety reason. When clutch pedal is pressed partially , it disengages gearbox, while when pressed completely P.T.O drive is cut off.

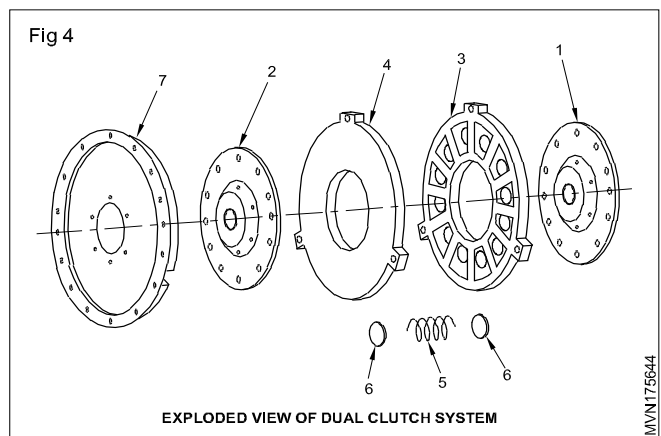

Dry and wet clutches: These clutches may be dry or wet. When the clutch is operated dry without oil, it is called a dry

clutch, but where the oil is used in the clutch it is called a wet clutch. Oil is used to cool the friction plate. The wet clutches are generally used along with or as a part of automatic transmission. These types of clutches are mostly used in heavy tractor and earth moving machineries.

Cone clutch (Fig 5)

In this case friction plates are in the shape of a cone. When the clutch is engaged the friction surfaces (4) of the male cone (2) on the clutch shaft (1) engage with the female cone (3) on the flywheel (5) due to the force of the spring. When the clutch pedal is pressed the male cone slides on the splines of the clutch shaft against the spring force. It gives more frictional area and is simple in construction. It is practically absolute and the same principle/device is used in the synchroniser unit in a synchro-mesh gear box.

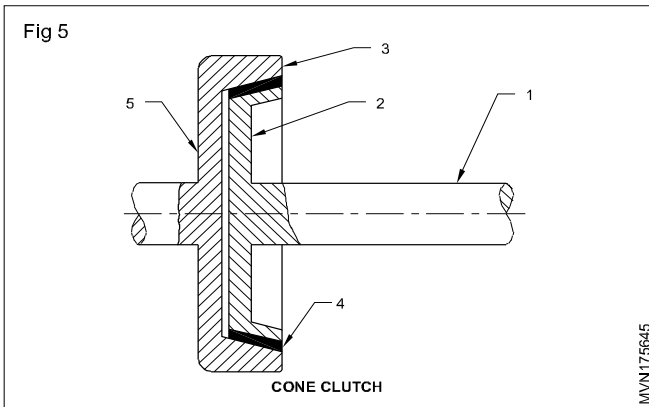

Dog clutch (Fig 6)

This type of clutch is used to lock two shafts together or to lock a gear to a shaft. When the sleeve (2) slides on a splined shaft (1) its internal teeth (5) match with the dog clutch (3) teeth of the driving shaft (4) and the clutch is engaged in this type there is no possibility of a slip as both the shafts revolve exactly at the same speed.

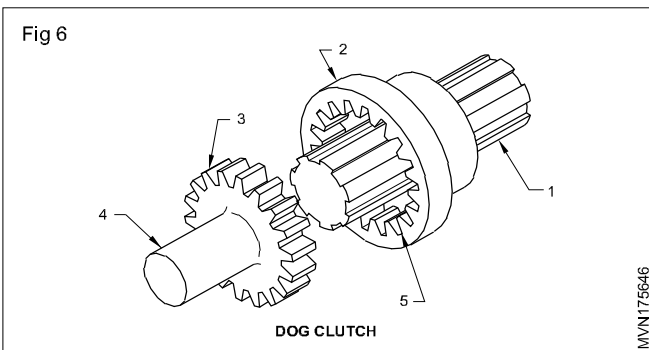

Diaphragm spring type clutch (Fig 7)

In some tractor, instead of using coil spring a conical dish shaped steel plate diaphragm spring (1) is used. It exerts force on the pressure plate (3) to press the clutch plate (4) firmly for engaging the clutch. It does not have release levers. The slots start from the centre of the diaphragm to form a number of release fingers (2). It requires very little pedal effort to disengage the clutch and it works noise free.

Fluid coupling (Fig 8)

Fluid coupling consists of two half shells fitted with interior fins (7) which rotate from the hubs. These unit are mounted very close to each other with their open ends. So that they

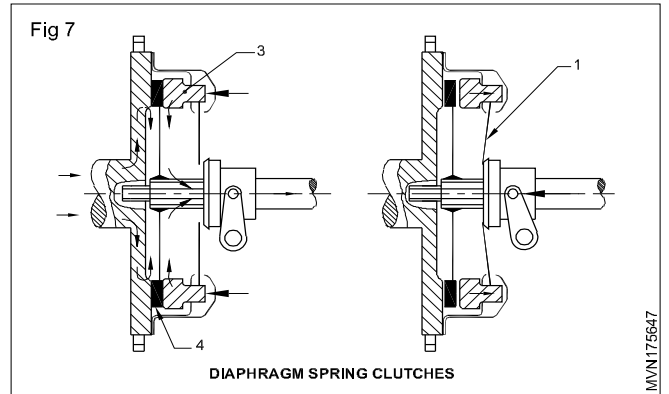

can turn independently without touching each other. A housing (5) surrounds both units to make a complete assembly inside, the assembly is fitted with 80% of fluid. The driving unit impeller (1) is linked to the crankshaft (2) rotates. The driven impeller (3) is mounted on the driven shaft (4) due to the movement of the oil, the impeller (3) rotates and transmits torque to the driven shaft (4).

Fluid coupling enables the driver to use the clutch and gear with less skill and fatigue than the conventional clutch. Wrong clutch engagements or selection of improper gear will not produce any of noise or sound. Any sudden load is also cushioned and absorbed by the fluid coupling. Dynamic stresses or breakages of the gear teeth of the mechanism and final drive are reduced to minimal. Fluid coupling is used with the epicyclic gear box as the output shaft (drive shaft) is always in motion.

