

Piston and piston rings

Objectives: At the end of this lesson you shall be able to

- state the function and the requirements of a piston
- state the constructional features of a piston
- list out the different types of pistons
- list out the different types of piston rings
- state the constructional features of piston rings
- list out the material of piston rings.

A piston is a cylindrical shape which reciprocates inside the cylinder bore. The main functions of the pistons are:

- to transmit the power developed by fuel combustion to the crankshaft through the connecting rod
- to transfer the heat generated due to combustion to the cylinder wall.

Requirements of a piston

A piston should be:

- able to withstand high temperature and pressure of combustion.
- a good conductor of heat.
- light enough to minimise the inertia load.

Construction of a piston

It has a special shape at different portions according to the design. A piston is designed with five portions according to the purpose and functional features.

The crown or head

It is the top most portion of the piston. It is subjected to high pressure and temperature due to the combustion of the fuel.

Four types of heads are used.

Flat head

It is simple in shape and is most commonly used. It is simple in construction. Decarbonising of this is very easy. (Fig 1)

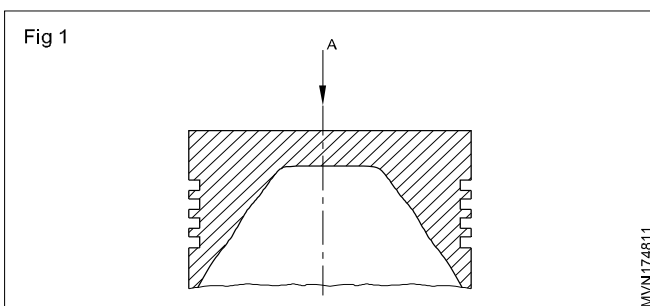

Domed head

It has a projection shaped like a dome on the crown. (Fig 2 & Fig 3) The dome acts as a deflector and helps to make a homogeneous mixture of air and fuel.

It is used in two-stroke cycle engines. It is difficult to manufacture compared to flat heads.

Concave head

It has a concave cavity on the top. (Fig 4) It is used in high compression diesel engines to reduce the clearance space.

170 Automobile: MMV (NSQF Level- 5) - Related Theory for Exercise 1.7.44 - 1.7.63

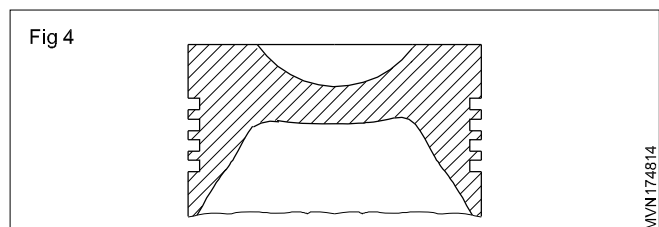
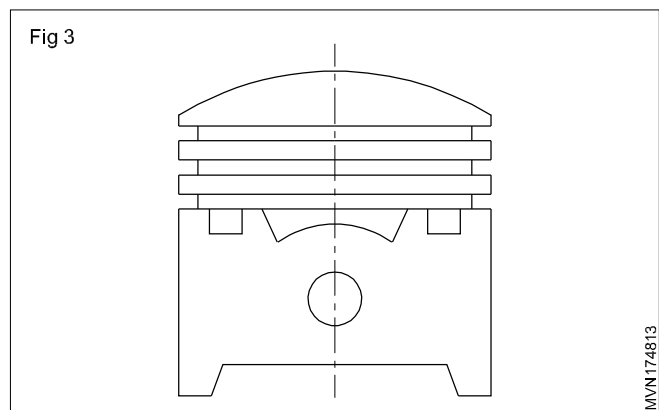
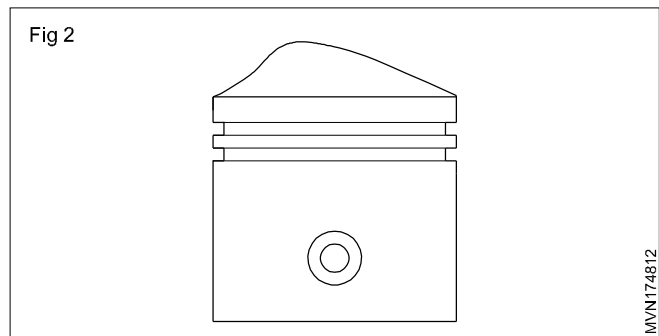

Irregular head (cavity piston)

It has a cavity on the top, (Fig 5) and a conical shaped projection is provided inside the cavity. This helps in swirling of air and thereby making for it better homogeneous burning, and it improves combustion. It is used in high compression diesel engines.

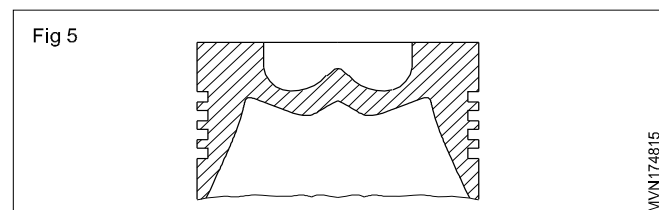

Skirt

Skirt is the lowest portion of the piston. It works as a guide to the piston in the bore and enables the piston to move in a straight line. The skirt has the least clearance with the liner. The piston to liner clearance is measured at the skirt.

Ring section

It is the portion between the top of the piston and the last ring groove. It has more clearance with the cylinder than with the skirt. There are two types of piston ring grooves. (Fig 6)

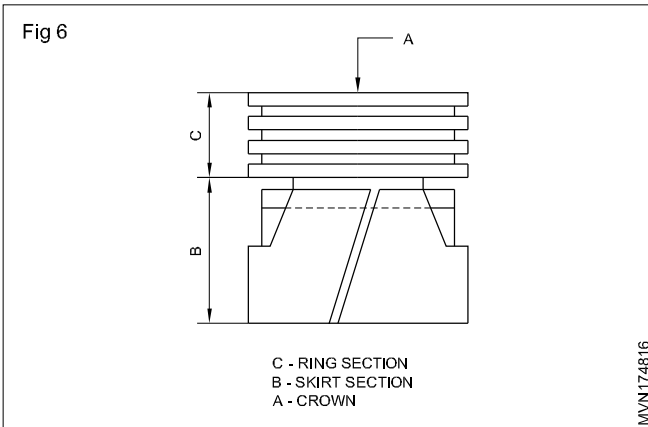

- Compression ring groove

These grooves accommodate compression rings.

- Oil ring groove

These grooves accommodate the oil scraper rings.

Land

This is the piston's circumference left above the top ring groove and between the ring grooves. (Fig 7)

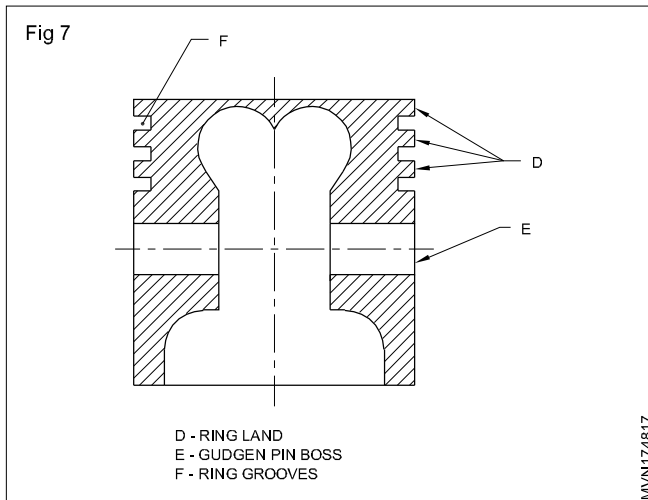

Gudgeon pin boss

At this portion (Fig 8) of the piston a gudgeon pin is fitted to connect the piston and the connecting rod. In some cases it is reinforced with ribs to withstand the combustion pressure. When the engine is running in clockwise direction, seen from the front of the engine, the left side of the piston is the maximum thrust side and right side is the minimum thrust side.

Designs/Types of pistons

Solid skirt piston

These pistons are used in compression, ignition engines or heavy petrol engines. This design can take heavy loads and thrusts. (Fig 9)

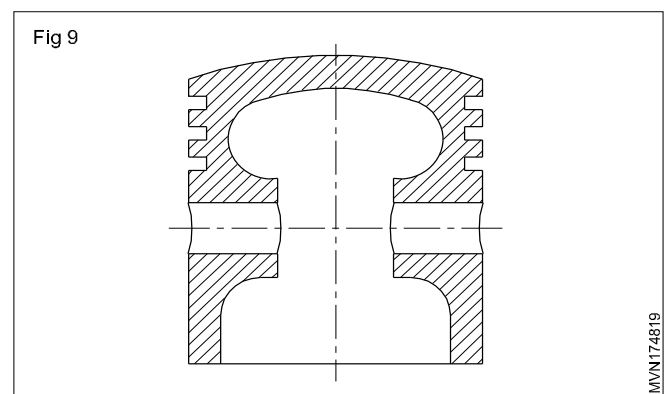
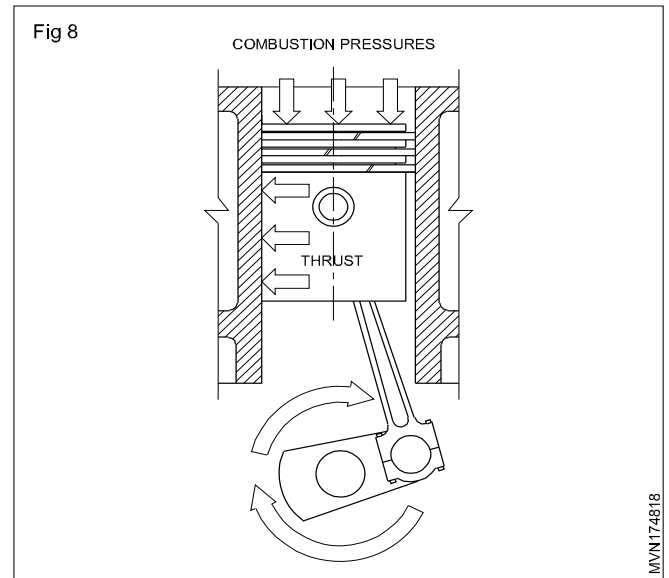

Slipper pistons

This type of pistons are used in modern engines to increase the area of contact at thrust faces. It is lighter in weight compared to the solid skirt piston. (Fig 10)

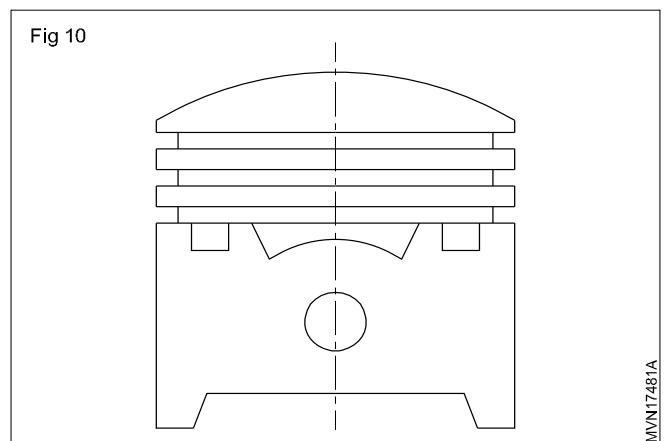

Split skirt piston

It is widely used in two-stroke scooters and mopeds. It is lighter in weight and has less inertia load. (Fig 11)

Piston with steel alloy inserts

Steel alloy inserts (1) are cast between the thrust faces on the inside of the gudgeon pin bosses. This gives strength and controls expansion of the piston at high temperature. (Fig 12)

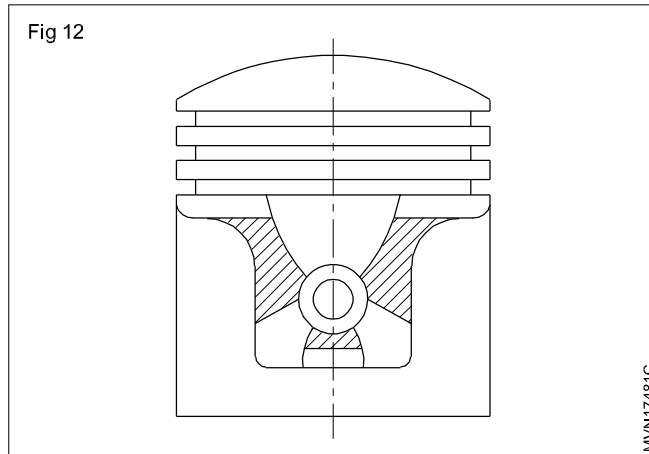
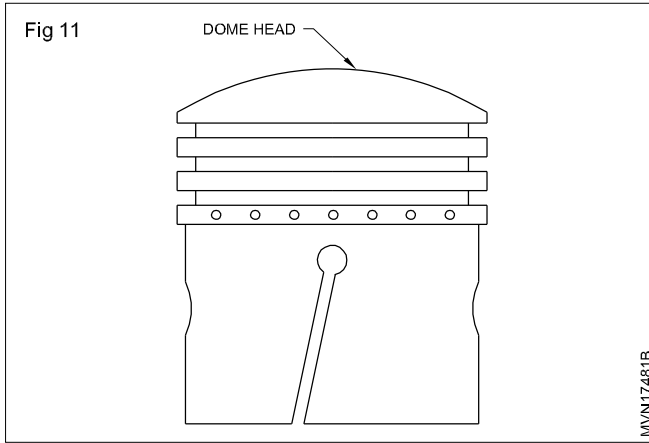

Steel-belted pistons

A steel ring is cast above the gudgeon pin boss for strength. It controls expansion. This type of pistons are used in heavy duty engines. (Fig 13)

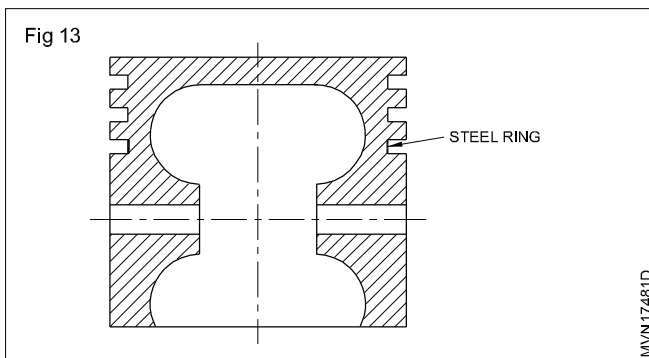

Cam ground pistons

The skirt of this piston is ground oval in shape. The diameter across the gudgeon pin boss axis is less at the thrust side. When the engine runs and the piston heats up, the bosses expand outwards making the piston round, and the clearance with the cylinder bore uniform all round. (Fig 14)

Constant clearance pistons (Slot skirts)

These pistons have one or two slots cut in the piston skirt. When the piston gets heated up, the width of the slots decreases. It helps in maintaining a constant clearance with the cylinder bore. These slots are located under the oil ring groove at the minimum thrust side. The end of the

slots is divided with holes to avoid stress concentration. (Fig 15)

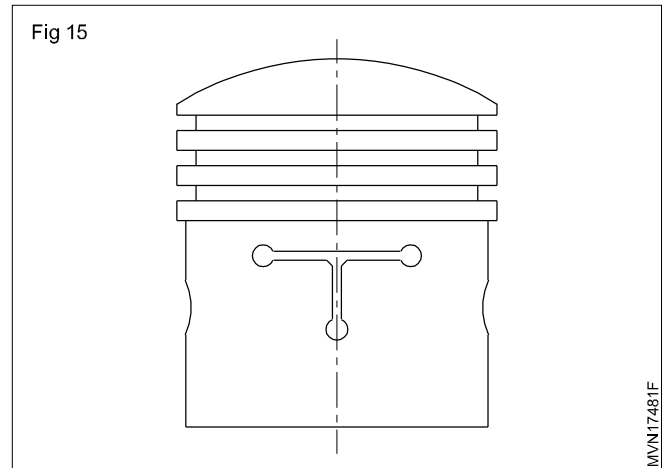
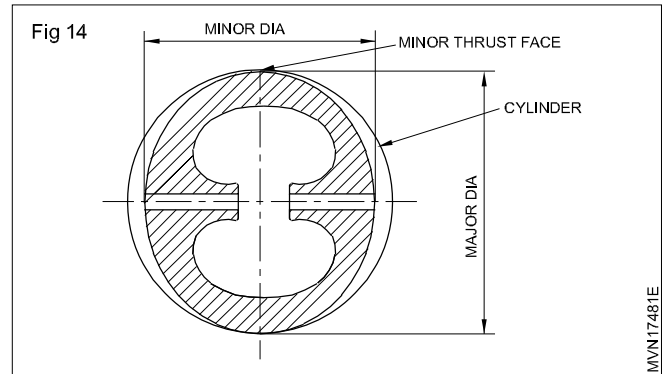

Heat dam pistons

These pistons have an extra groove (1) cast in between the top ring groove and piston crown. It is known as heat dam. It reduces the heat path on the piston head to the skirt. It enables the piston to run cooler. In this groove no ring is fitted. (Fig 16)

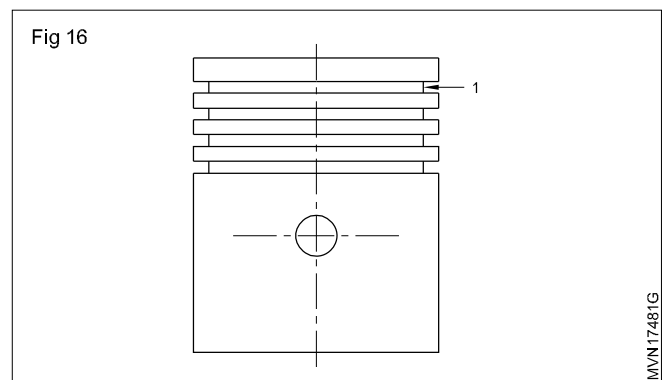

Alfin piston/ring carrier piston

Wear in the ring groove will result in excess oil reaching the combustion chamber. To reduce the wear on the top ring groove in piston(3), a ferrous ring (1) is inserted. This insert reduces the wear of the top ring groove (2). (Fig 17)

Piston rings

Types

- Compression ring
- Oil control ring

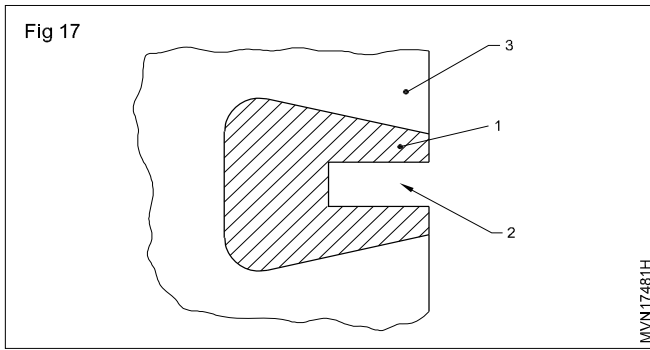

Compression rings

These rings effectively seal the compression pressure and the leakage of the combustion gases. These are fitted in the top grooves. They also transfer heat from the piston to the cylinder walls. These rings vary in their cross-section.

The following types of compression rings are used.

Rectangular rings

These rings are very popular and easy to manufacture at a lower cost. The face of the rings (1) remains in full contact with the wall of the liner (2). (Fig 18)

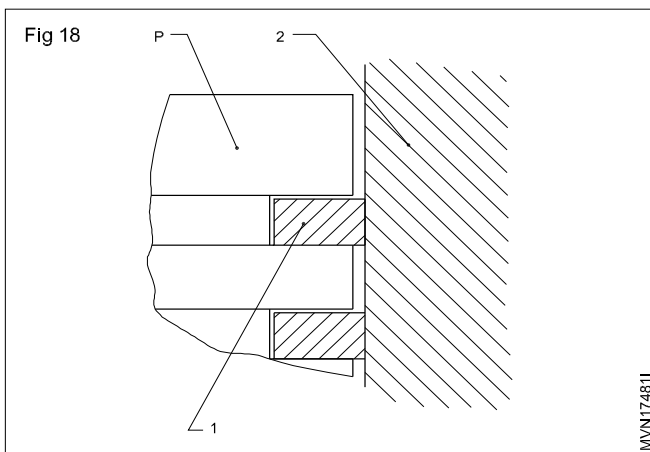

Taper-faced rings

The face of the ring (1) is tapered (Fig 19). The lower edge of the ring is in touch with the liner (2). These rings are good for controlling oil consumption by scraping all the oil from the liner (2). These rings cannot effectively control blow-by.

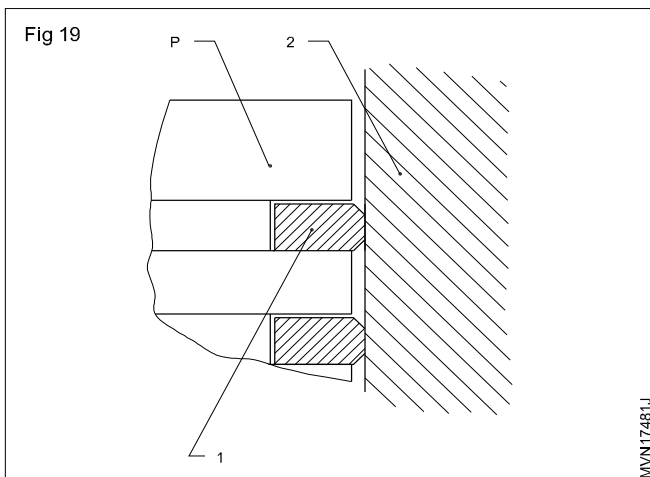

Barrel-faced rings

In this type, the corners of the rings (1) are rounded off to give a barrel shape. These rings are used only for top grooves to prevent blow-by. (Fig 20)

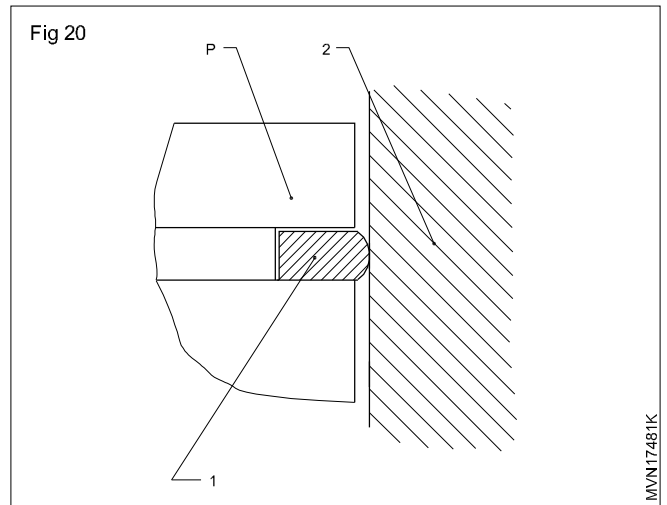

Inside bevel rings

In this type a step is cut on the top surface at the inner diameter of the ring (1). The step allows the ring to twist slightly when the piston moves. It is more effective in preventing blow-by. These rings are used in second grooves. (Fig 21)

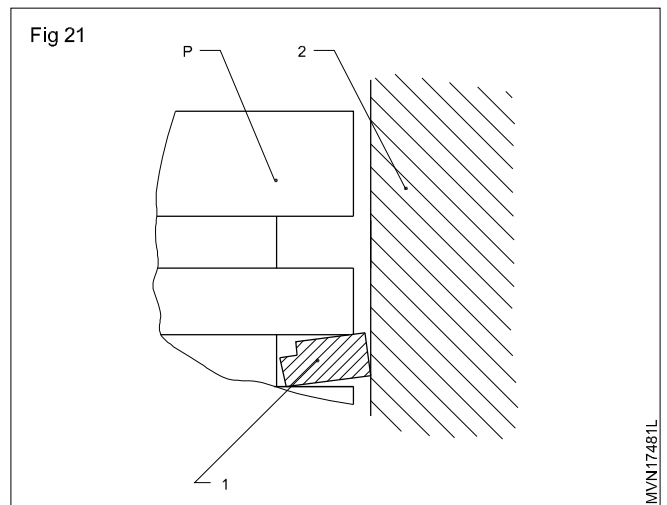

Keystone ring

This types of rings (1) does not allow carbon to settle in the ring groove. It is generally used in heavy vehicles. (Fig 22)

Joints of compression rings

Step joint

It is considered to be one of the best to prevent blow-by. It is difficult to manufacture, and to set a correct gap while fitting. These types of joints are not used much in automobiles. (Fig 23)

Angle joint (Diagonal cut)

This type of joints is easy to manufacture and the gap can be set quickly. It is commonly used in automobiles. (Fig 24)

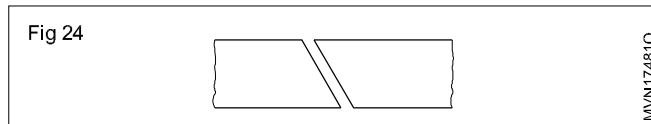
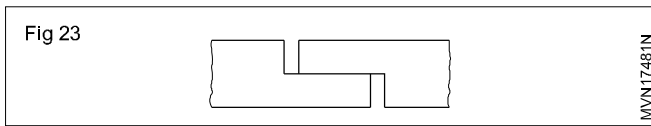
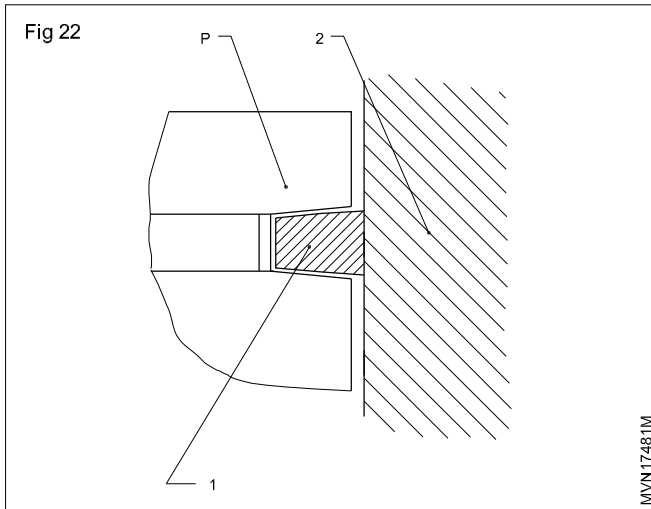

Straight joint

These rings are easy to manufacture and the gap can be set easily. Most of the engine rings have straight joints. (Fig 25)

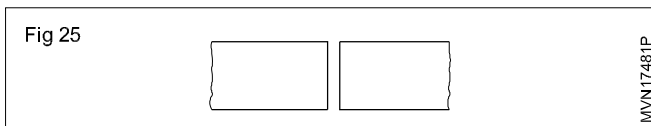

Oil control rings

The main purpose of an oil ring (2) is to scrape the excess oil from the liner and drain it back to the oil sump during the downward movement of the piston. It prevents the oil from reaching the combustion chamber. One or two oil control rings are used in a piston. If two rings are used, one is fitted above and the other is fitted below the gudgeon pin in the piston.

These rings exert enough pressure on the cylinder wall to scrape the oil film. To keep the sealing and avoid metal-to-metal contact, a thin film of oil stays on the liner. These rings are provided with drain holes or slots. These slots allow the scraped oil to reach the oil sump through the piston holes.

Types of oil scraper rings

One piece (Solid rings)

These rings are easy to install. They have greater force against the cylinder wall and reduce oil consumption.

Duraflex rings (Three pieces)

These rings (Fig 26) are used specially for re-ringing jobs, where the cylinder has worn out excessively. One set of

rings consists of rails, a crimped spring and expander. The rail (1) is of a circular shape. It is made of high quality, polished spring steel. The number of rails vary in accordance with the width of the groove. It wipes oil from the liner. The crimped spring (2) keeps the rail space apart and seals the top and bottom of the groove. It ensures the ring tightens in the groove irrespective of wear. The expander (3) exerts the correct amount of pressure against the rail and provides a sealing effect on the cylinder wall. The main advantage of this type of ring is that it provides enough pressure irrespective of cylinder wear in all conditions.

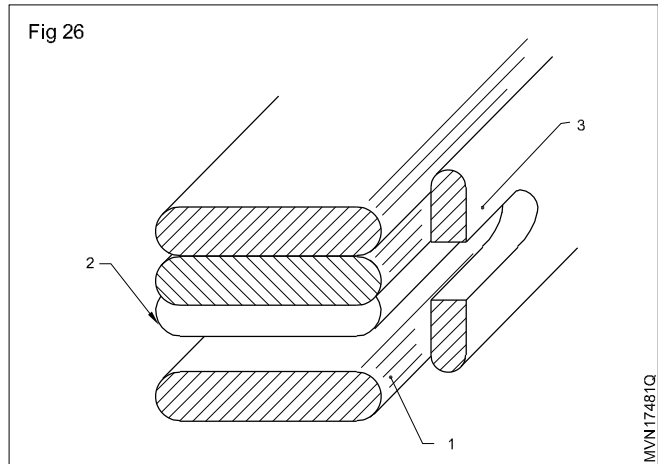

`T' Flex rings

It has one `T' shaped expander (1) with two scraper rails (2). The rails (2) also serve as spacers. The expander (1) forces the rails (2) against the cylinder wall. This enables the ring to scrape excess oil. The steel rail provides an effective side sealing of the cylinder walls. (Fig 27)

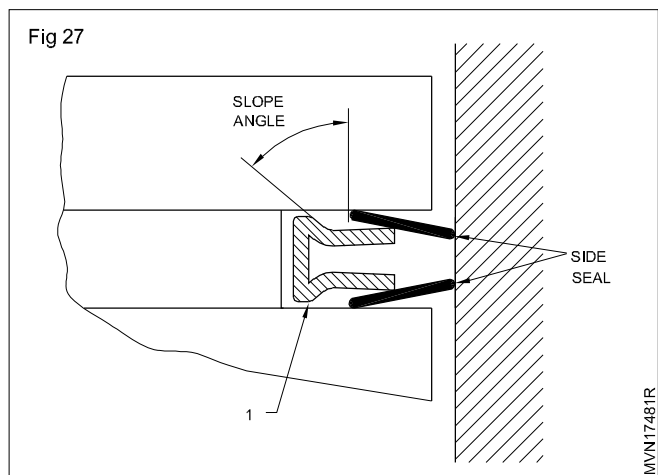

Materials

Piston rings are made of high grade cast iron, centrifugally cast and ground. This provides good elasticity, and minimises vibration. In some cases steel-chromium plated rings are also used in cast iron cylinders. Chromium plated rings are only used in the top groove.

These rings have less friction, less wear and longer life.

Piston ring

Objectives: At the end of this lesson you shall be able to

- state the recommended clearances for rings
- state the piston rings fitting precautions
- state the causes and remedies of piston rings
- state the compression ratio.

Piston clearance

Piston rings have gap so that they may be installed into the piston grooves and removed when worn out by expanding them. The gap ensures radial pressure against the cylinder wall thus having effective seal to prevent leakage of heavy combustion pressure. This gap must be checked because if it is too great due to cylinder bore wear, the radial pressure will be reduced. To check this gap clean the carbon from the ends of the ring and then check it with feeler gauges. This gap may be in the region 0.178 - 0.50 mm governed by the diameter of the bore but if it exceed 1 mm per 100 mm of bore diameter, new rings must be fitted. Fig 1

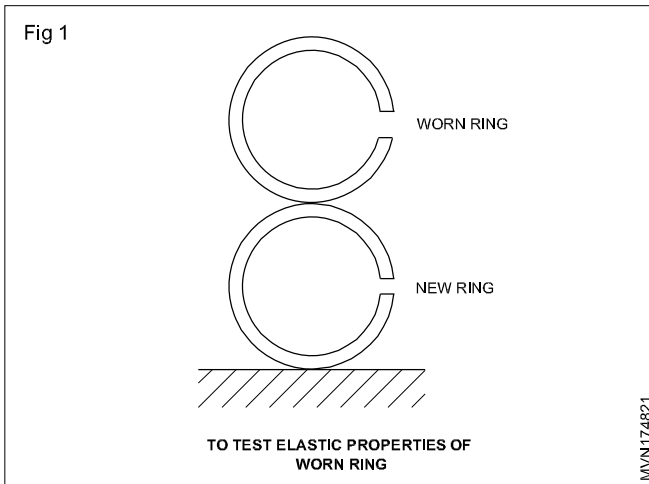

The gap between the ring and the groove in the piston should also be checked by feeler gauges. This gap is usually 0.038 - 0.102 mm Fig 2 for compression rings and a little less for the oil control rings.

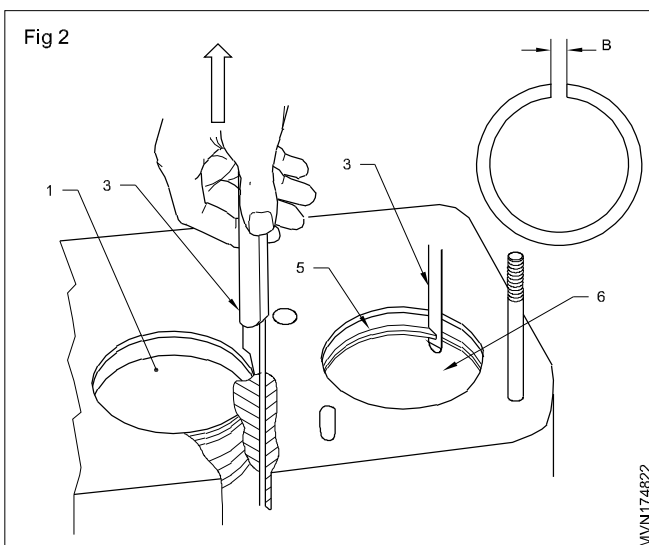

The gap between piston and liner is measured by feeler gauge from the bottom of the liner (skirt) is 25.4 mm Fig 3.

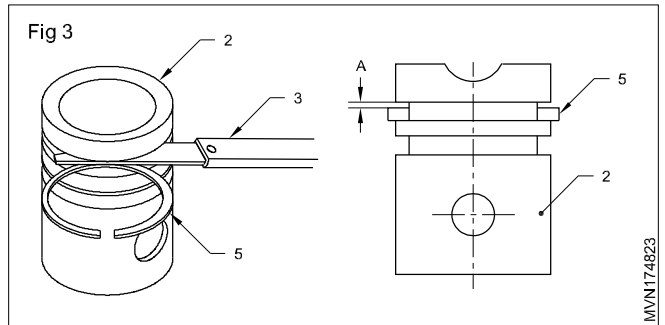

Precautions while fitting rings in the piston

There are two types of piston rings (compression ring and oil scraper ring) used in an i.c engines. While fitting the piston rings follow the precaution.

- 1 Remove the ridge in the liner.
- 2 Use proper ridge cutter.
- 3 Measure the end gap of new ring.
- 4 Use piston ring cutter to remove excess material.
- 5 Use piston ring grooves cleaner to remove carbon from groove.
- 6 Clean the piston groove, liner rings with specified cleaning liquid.
- 7 Excess piston ring expand lead broken, so limit the ring expansion as need
- 8 Use the ring expander to fit the ring in the piston.
- 9 Check the end gap clearance of the ring.
- 10 Check ring side clearance in the piston's groove.
- 11 Ensure the piston rings and gap should not be inline.

Causes and remedy

- 1 Wear in the piston ring grooves causes the rings to rise and fall during movement of piston and its pumping action resulting in high oil consumption.
- 2 Exercise gas blow by, loss of compression will also take place if gap is too much (cylinder wall and piston ring).
- 3 During service the piston ring may have lost some of its elastic properties due to which radial pressure will be reduced on the cylinder wall. This properly can be checked by pressing together worn and a new ring and observing whether the gap of the worn ring closes more than the new ring.

Compression ratio

It is the ratio of the volume of the charge in the cylinder above the piston at bottom dead centre and the volume of the charge when the piston is at top dead centre. Since the volume above the piston at bottom dead centre is the displacement of the cylinder plus the clearance volume; and the volume above the piston at top dead centre is the clearance volume, the compression ratio can be stated as:

$$\frac{\text{Clearance volume} + \text{Displacement volume}}{\text{Clearance volume}}$$

For example, if clearance volume is 90 cm³ and displacement volume is 540 cm³, the compression ratio will be,

$$r = \frac{90 + 540}{90} = \frac{630}{90} = 7 : 1$$

The compression ratio 7:1 is illustrated in Fig.4. Early automobile engines had low compression ratios 3:1 to 4:1. They are known as low compression engines. The fuel available at that time could not be subjected to greater pressure without detonation. The modern gasoline engines have compression ratios 7:1 to 10:1. Diesel engines have much higher compression ratios from 11: to 22:1.

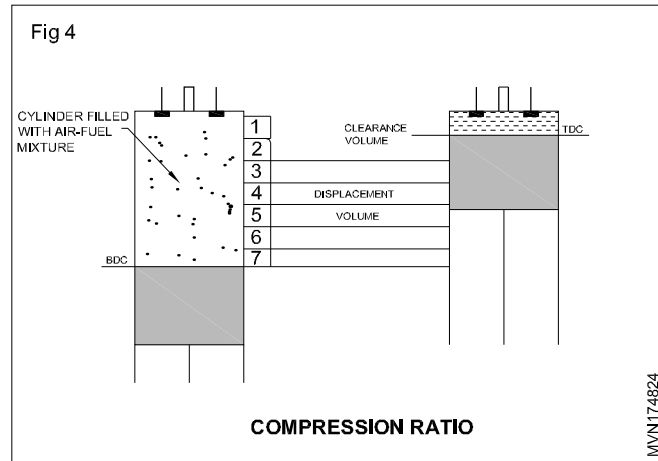

The compression ratio of an engine will be increased by any condition that will decrease the size of the clearance volume such as the accumulation of carbon deposits. High compression ratio results in decreased operating efficiency and greater power output for a given engine.

The pressure of the mixture at maximum compression is determined by the compression ratio. Some other factors are also considered like engine speed, temperature, degree of vaporisation of the fuel and leakage past the piston rings.

Description & function of connecting rod

Objectives: At the end of this lesson you shall be able to

- describe the function of connecting rod
- describe the construction and materials of big and small end bearing of connecting rod.

Connecting rod

Functions

It is fitted in between the piston and crankshaft. It converts the reciprocating motion of the piston to the rotary motion in the crankshaft. It must be light and strong enough to withstand stress and twisting forces.

Construction

The connecting rod (1) (Fig 1) is made of high grade alloy steel. It is drop-forged to 'I' shape. In some engines aluminium alloy connecting rods are also used. The upper end of the connecting rod has a hole (2) for the piston pin (3). The lower end of the connecting rod (1) is split, so that the connecting rod can be installed on the crankshaft. The top and bottom halves (5) of the lower end of the connecting rod are bolted together on the big end journal of the crankshaft, by bolt and nut (4).

A large bearing area is provided to take the load, heat and wear. The split halves are usually fitted with babbitt bearings (6) or bearing lining steel-backed copper lead. In the upper end of the connecting rod a bronze bush (7) is fixed. The small end of the connecting rod is connected to the piston (8) by means of a piston pin (3).

In some engines a hole (9) is drilled in the connecting rods from the big end to the small end. It allows oil to flow from the big end to the small end bush.

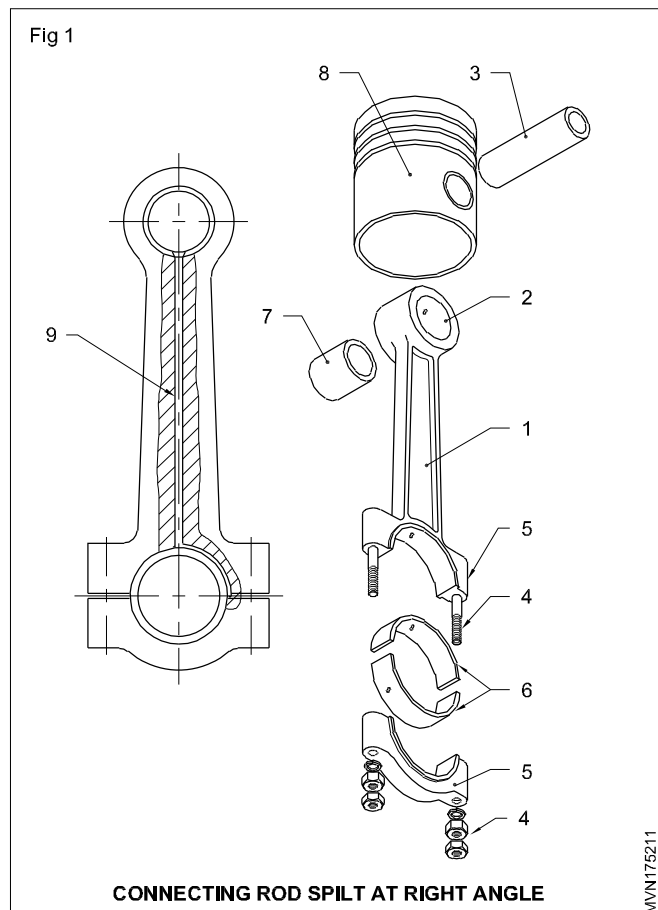

Control split at an angle (Oblique cutting) (Fig.2)

The connecting rod big end is split at an angle for assembly easily on the crankpin.

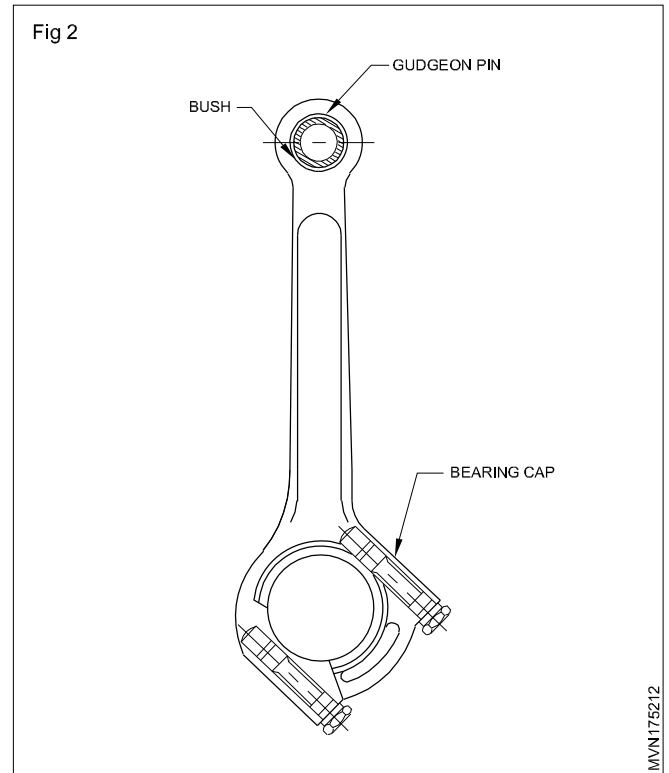

Locking methods of piston pin

Objective: At the end of this lesson you shall be able to

- list out the various types of piston pins locking method and material of the position pin.

The piston pin or gudgeon pin connects the piston with the connecting rod. It should be strong enough to transmit power and withstand pressure of combustion. Piston pins are made hollow to reduce inertia load due to the reciprocating motion.

Types of piston pins

Fully floating piston pin

In this type (Fig 1) there are two circlips (1) on either side of the piston pin (2). The pin (2) is free to rotate both in the piston (3) and the connecting rod. Circlips (1) are fitted into the grooves provided in the piston boss. This type of pins is used in engines which carry heavy loads. The gun metal or bronze bush is used between the small end of the connecting rod and the piston pin. Small two-stroke engines may have a needle bearing cage instead of a bush.

Semi-floating piston pin

The pin (1) is fastened to the connecting rod (2) with a clamp (3), screw (4) and nut. In this the piston boss forms the bearing. (Fig 2)

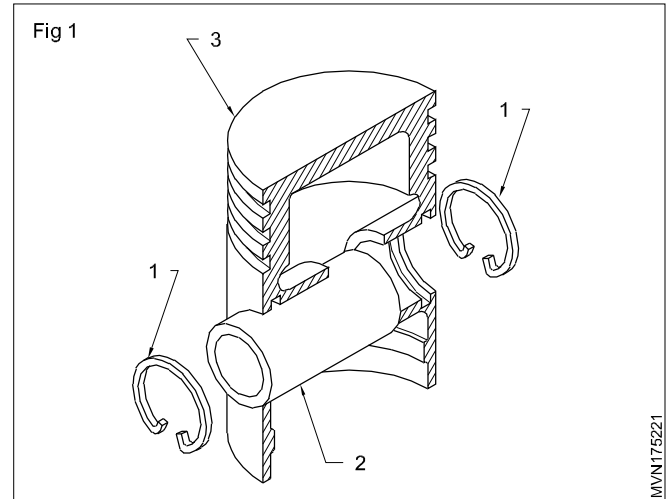

Set screw type piston pin

The pin (1) is fastened to the piston (2) by a set screw (3) through the piston boss and is provided with a bush in the small end of the connecting rod. (Fig 3)

Piston pin materials

The piston pin are made of Nickle / chromium alloy steel. The outer surface is ground, chromium plated and case hardened.