

**Valves**

**Objectives:** At the end of this lesson you shall be able to

- describe the function of the valve
- state the constructional features of valves
- list out the different types of valves and their material.

**Functions of valves**

- To open and close the inlet and exhaust passages of the cylinder.
- To dissipate heat, through its seat to the cylinder head.

**Construction of a valve**

The head (1) of the valve is ground with a margin (2) to provide strength. (Fig 1)

The valve face (3) is ground to 30° or 45° angle which matches with the seat angle to avoid leakage. The valve stem (4) is of a round shape. The length of the stem varies from engine to engine. At the end of the stem a groove (5) is provided to hold the spring lock.

In some heavy duty engines, the valves are hollow, and sodium is filled inside, which helps in the quick cooling of the valve.

**Types of valves**

- Poppet-valves (Fig.1)
- Rotary valves (Fig.2)
- Sleeve valves (Fig.3)
- Reed valves (Fig.4)

**Poppet-valves**

As the name indicates these valves pop on their seat. Three types of poppet-valves are in use.

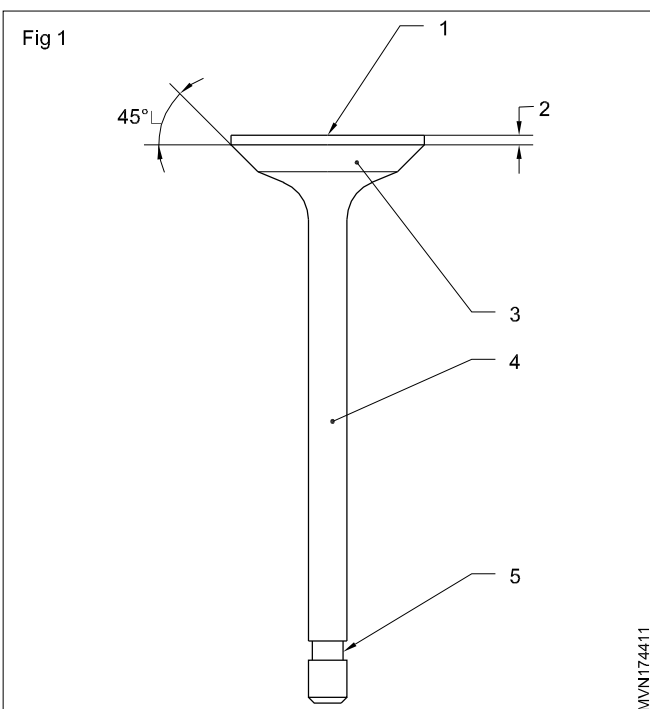

- Standard valve
- Tulip valve
- Flat top valve

**Rotary valve (Fig.2)**

In this type a hollow shaft runs in the housing which is attached to the cylinder head. This hollow shaft has two ports cut in it, and it aligns the opening in the cylinder head with the inlet manifold, and at the time of the exhaust stroke its opening aligns with the exhaust manifold. (Fig 2 & 3)

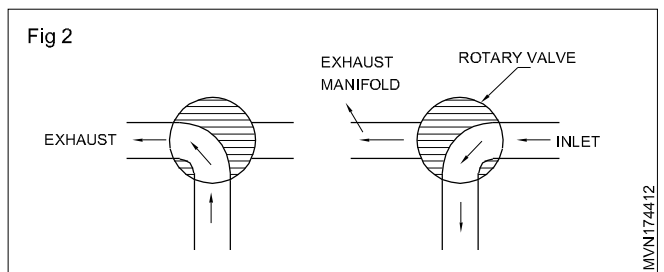

**Sleeve valve (Fig.3)**

In this type, ports are cut in the cylinder liner. It runs with a slight up and down motion. It is also having rotary motion in another sleeve. This aligns with the inlet and exhaust ports at a set time when the inlet and exhaust manifold open.

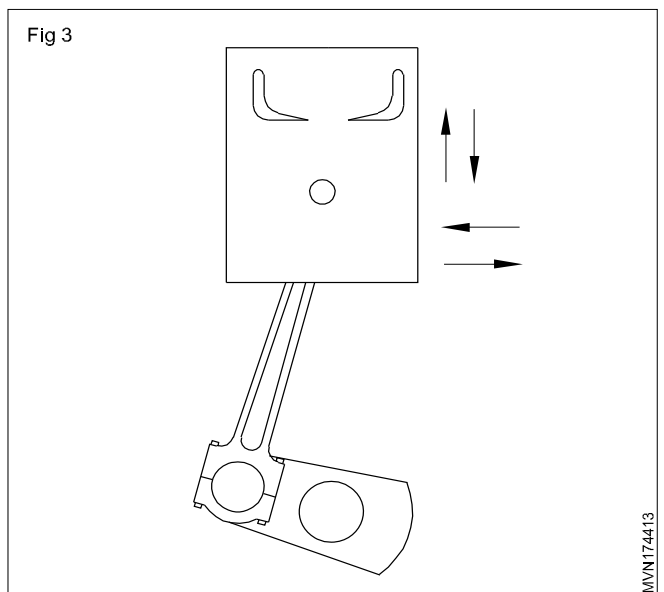

**Reed valve (Fig.4)**

It is a metallic strip hinged at one end. It covers the passages and allows air or charge to flow in one direction only. It is normally used in two-stroke engines and air compressors.

Fig 4

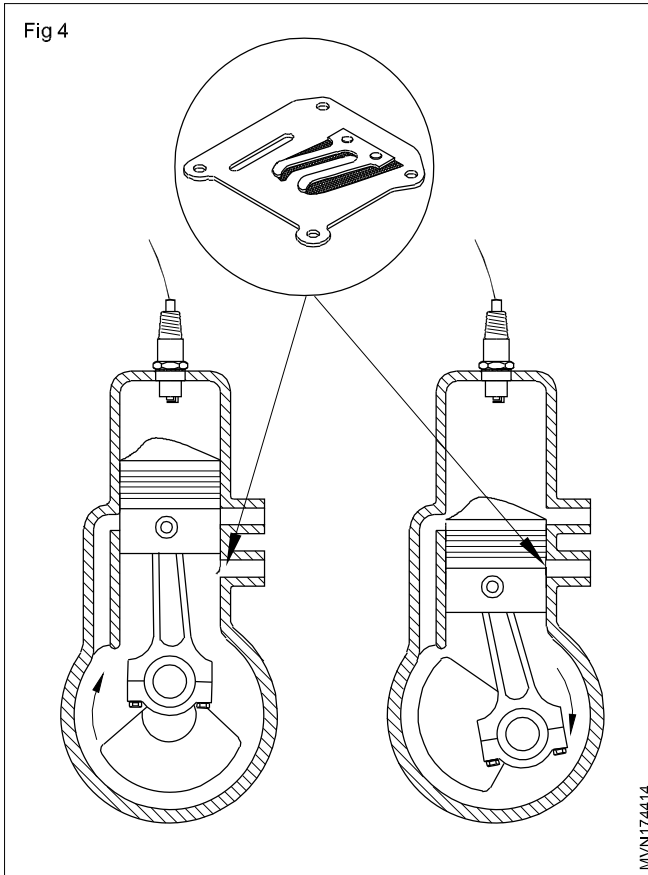

MVNI74414

### Valve Materials

Inlet valve - Nickel steel alloy stellite facing

Exhaust valve - Silicon - chrome alloy steel sodium filled valves

## Valve operating mechanism

**Objectives:** At the end of this lesson you shall be able to

- state the requirements of valve operation
- state the types of valve operating mechanism
- list out the parts of the valve mechanism
- state the importance of valve seats
- method of valve seats inserts in cylinder heads.

### Requirements for valve operation

- 1 Valve must seat tightly and properly on its seat.
- 2 Valve must be properly timed.
- 3 Valve must be operate without log.
- 4 Valve tappet clearance must be correct.
- 5 Valve stem and guide clearance must be correct.

### Valve operating mechanisms

Two types of value operating mechanisms are used in engines. They are as follows.

- Slide valve mechanism
- Overhead valve mechanism

In overhead valve mechanism, the position of camshaft is considered as the types of valve mechanism i.e.,

- 1 Single overhead camshaft mechanism
- 2 Double overhead camshaft mechanism

**Side valve mechanism (Fig.1):** In the side value mechanism both the inlet and exhaust valves are fitted in the cylinder block.

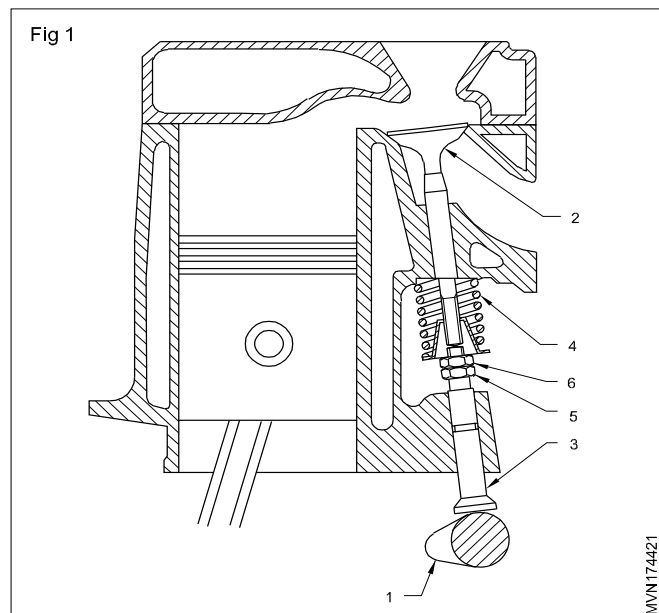

MVNI74421

**Overhead valve mechanism (Fig 2):** In this mechanism, the valves are located in the cylinder head. Push-rods and rocker arms are used in addition to the side valve mechanism.

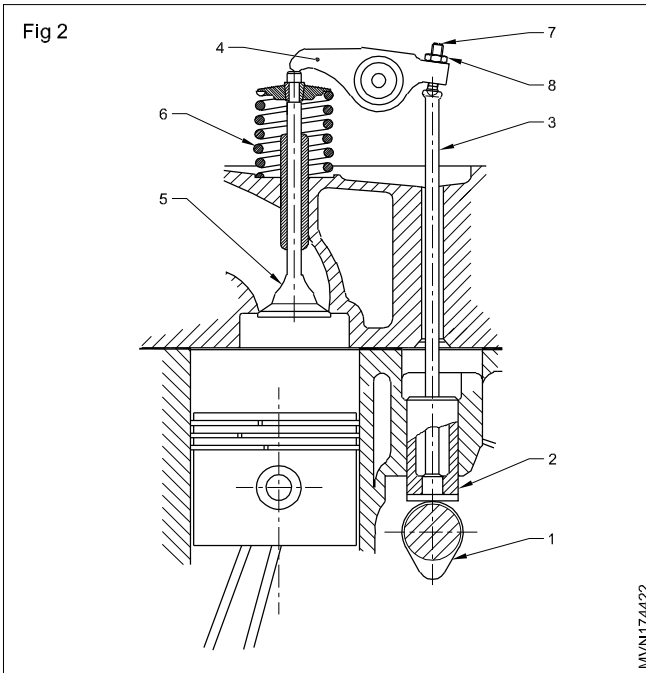

### Working

When the cam shaft rotates, the cam lobe (1) lifts the tappet (2) upward. When the tappet (2) moves up, it pushes the push-rod (3) and one end of the rocker arm upwards. The other end of the rocker arm's (4) tip, moves downward and the valve (5) opens against the spring's (6) tension.

When the cam lobe (1) reaches the maximum height, the valve opens fully. Further rotation of the cam shaft causes the tappet (2) to move down and the valve is closed by the tension of the spring (6).

Tappet clearance is provided in between the valve (5) tip and the rocker arm's (4) tip. This clearance can be adjusted by the adjusting screw (7) and the lock-nut (8).

In many cases, even these rockers or followers (Fig 3) and their pivots are dispensed with and the valves are actuated directly by the camshaft through bucket type.

**Importance of valve seats (Fig.3):** Valve and valve seats are ground to correct and shape so that the valve may seat properly on the seat for effective valve seating and sealing. The valve face angle must match the valve seat angle. Valve seating and sealing is closely related to the engine performance.

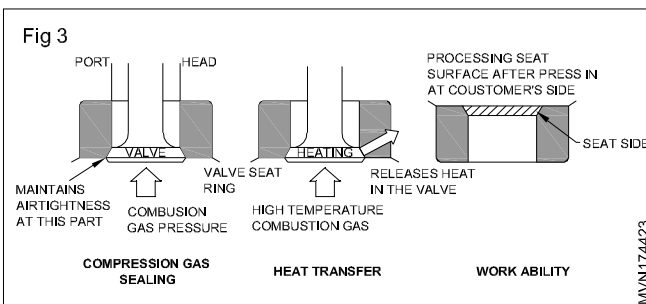

### Function of valve seats (Fig 4)

- 1 Compression gas sealing prevents compressed gaseous bodies and combustion gas from leaking into the manifold.

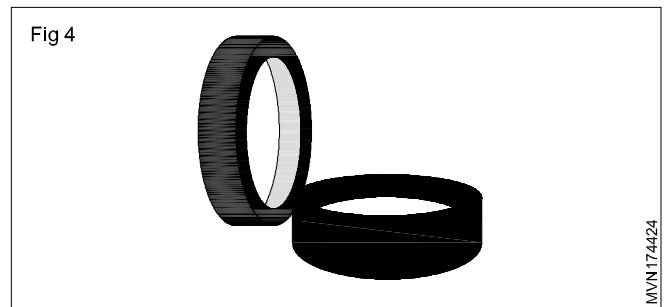

- 2 Heat transfer releases heat in the valve to the cylinder head.
- 3 Strength holds tight when the valve is mounted.
- 4 Wear-resistance hard to wear down under high heat and high load.

### Importance of valve seats inserts in cylinder head

**Hydraulic tappet:** Hydraulic tappets (Fig 5) enable the valve gear to operate without fixed clearances. They consist of the tappet body, the tappet piston, a ball valve with spring and the clearance eliminating spring. When the engine is running, lubricating oil from the oil pump is forced through an oil way to the tappet. It flows through the outer chamber (to lubricate the tappet itself) and hence to the inner chamber (plunger lubrication) and to the interior of the piston. By way of a filling bore, the oil passes through the ball (check) valve to the pressure chamber. The clearance eliminating spring (Fig 6) forces the tappet piston to prevent any valve clearance from occurring. When the cam lifts the tappet, the ball valve closes and the oil-filling the pressure chamber acts as an almost rigid link. Thermal expansion of valve gear components is compensated for by precisely calculated oil loss as a result of tappet piston operating clearance. Although hydraulic tappets are heavier and therefore suffer from increased inertia, this drawback can be compensated for an engines which operate the valves by followers from the overhead camshaft. On these engines, the hydraulic clearance adjuster can be installed in the follower mount instead of in the tappet; it is of similar design to the hydraulic tappet just described.

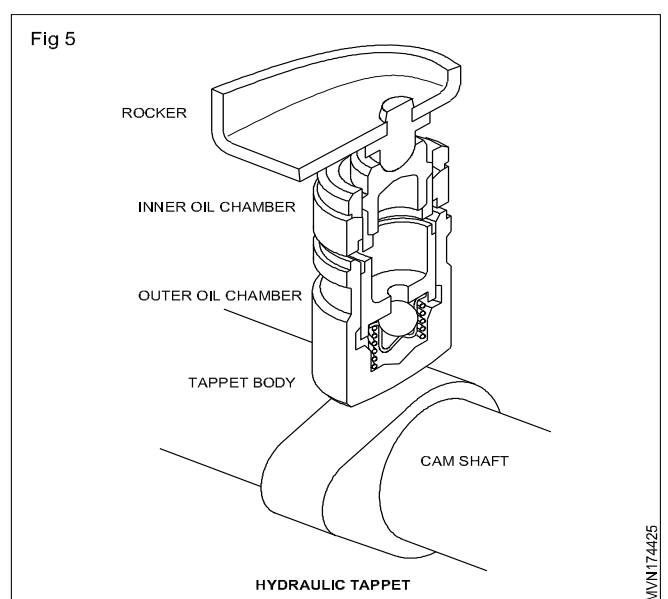

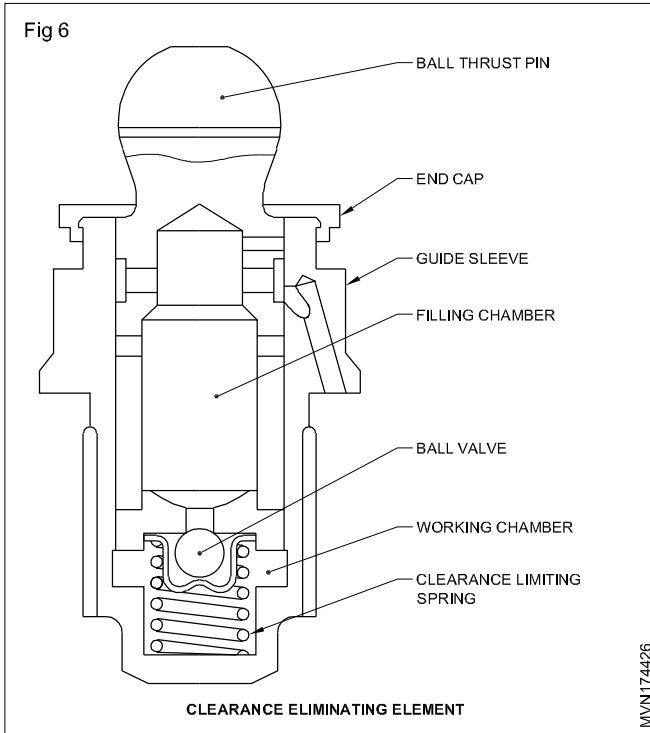

### Types of valve arrangement

1 Two valve arrangement in one cylinder Fig.7

- A One inlet valve
- B One exhaust valve

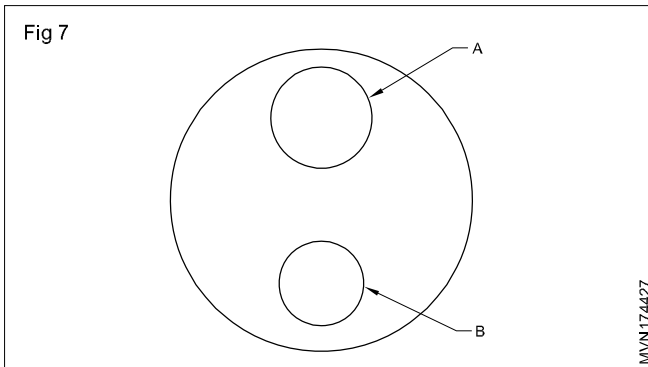

2 Three valve arrangement in one cylinder Fig 8

- A Two inlet valves
- B One exhaust valves

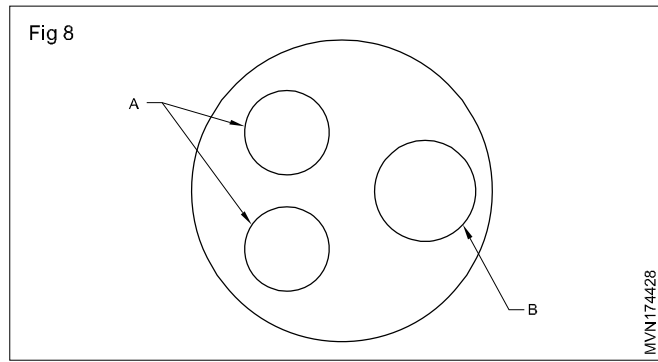

3 Four valve arrangement in one cylinder Fig 9

- A Two inlet valves
- B Two exhaust valves

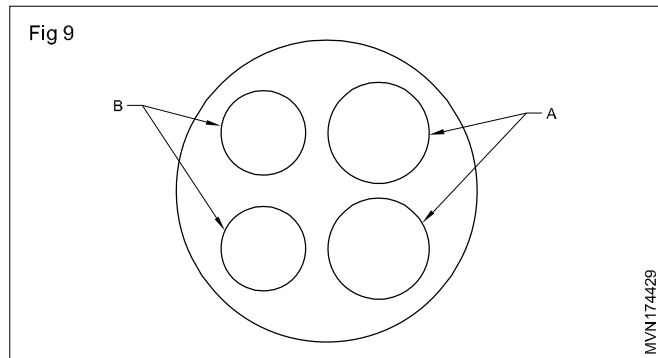

4 Five valve arrangement in one cylinder Fig 10

- A Three inlet valves
- B Two exhaust valves

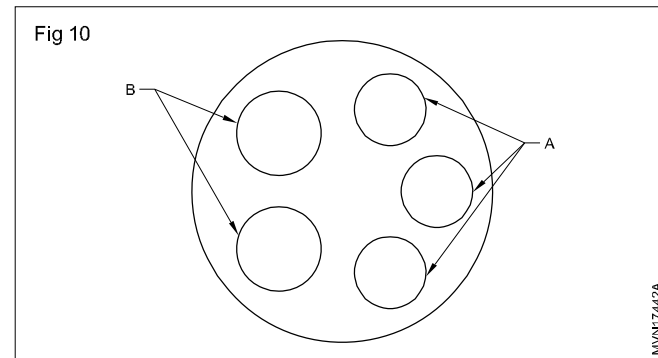

## Valve constructional features and valve timing

**Objectives:** At the end of this lesson you shall be able to

- state the function of valve rotation
- state the function of valve stem oil seals
- state the size of intake valve
- describe the valve trains
- explain valve timing
- state the of variable valve timing.

### Valve rotation

The main scope of the valve and tappet rotation is to reduce the wear, the friction and increase the life period of the components and maintain the conical valve face and seat clean of carbon deposit that might appear on surfaces

during valve opening. To uniform the thermal stress of the valve head because of the asymmetry exhaust manifold and uniform the wear of the conical face providing a good sealing of the cylinder.

If the valve is rotating the contact point between valve head and seat will vary and in this way the wear marks or cranks can be avoided. Valve rotation is the uniformity of the oil film in the valve guide on the valve stem. Auxiliary rotation system is rotate the valve during opening or closing period on those systems components are rotocap, turnomat, rotocoil, rotomat, duomate.

The tappet rotation reduce the wear caused by the contact with the cam, improves the lubrication of those two surfaces and increases the tappet life.

Valve rotation mechanism of an engine (Fig.1)

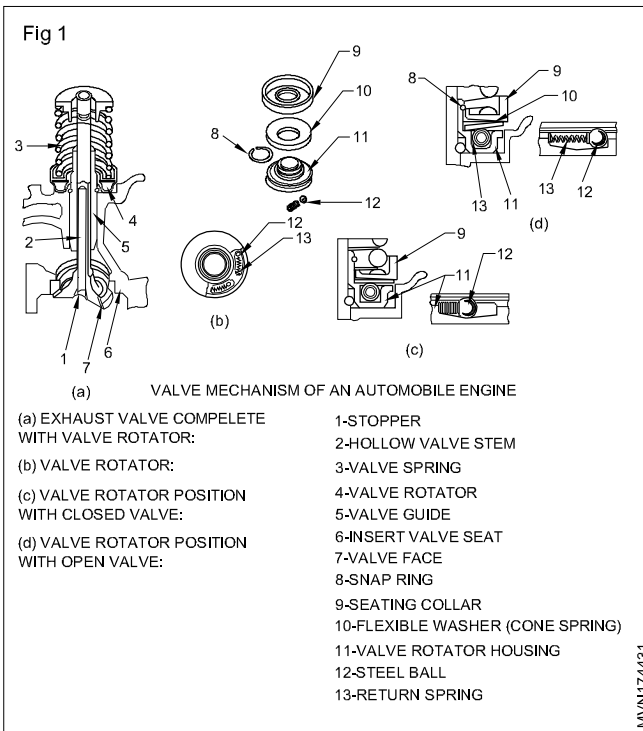

**Function of valve stem oil seal (Figs 2 & 3)**

The purpose of the valve stem oil seal is to prevent the oil from the cylinder head entering the combustion chamber. Valve stem seals play a critical role in controlling valve lubrication as well as oil consumption.

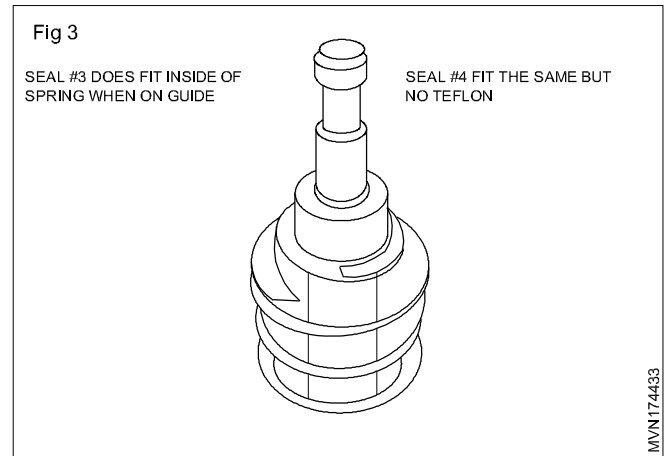
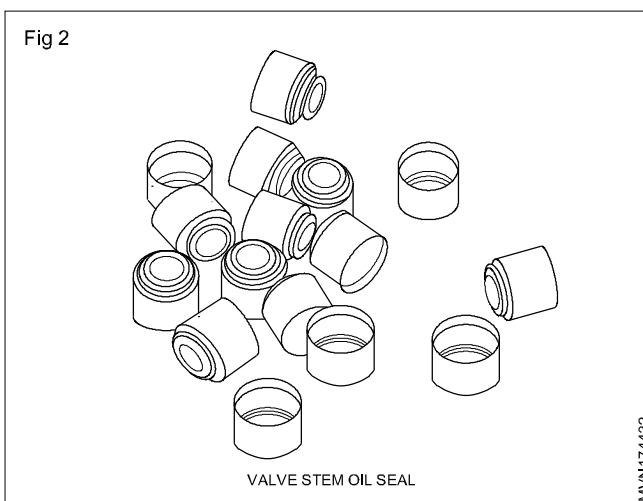

There are two basic valve stem seal designs

- 1 Deflector seals - also called umbrella seals, deflect oil away from the valve stem. They are secured to the valve stem and move with the valve to shield the valve guide from excess oil. Umbrella type seals were commonly used prior to the development of positive type seals.
- 2 Positive seals - attach to the valve guide boss and function as squeegees, wiping and metering oil on the stem as they pass through the seals. State the size of in take valve.

Exhaust valves are made to close certain degrees after T.D.C. to develop a suction effect by the outgoing gases. It also helps in the scavenging of the exhaust gases by using the intake charge's momentum.

Causes the engine suck oil down the guides and into the cylinder

- Seal worn
- Seal cracked
- Seal missing
- Seal broken
- Seal improperly installed

When stem oil seals lose their ability to control the oil that enters oil through the guide, that can cause a variety of problem.

- Excessive smoke
- High oil consumption
- Carbon deposited in valve and piston
- OFF - throttle braking
- Running engine OFF in idle speed.

**Valvetrain:** (Fig.4) The valve train of an internal combustion engine includes components required to control the flow of gases into and out of the combustion chamber valves and related component required to allow the air or air fuel mixture to enter the combustion chamber, the combustion chamber during compression and combustion and evacuate exhaust gases when combustion is complete. This type of valve train used for a reciprocating engine depends on the engine design and whether the engine is a four /two stroke cycle unit.

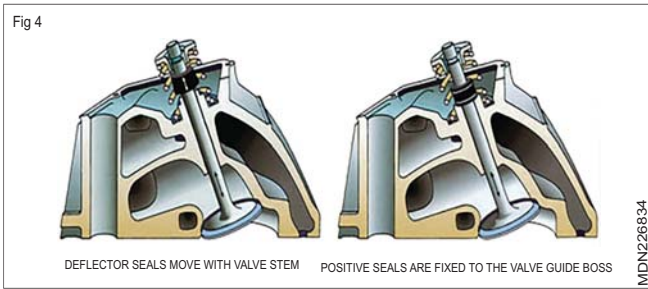

**State the size of intake valve (Fig.5)**

In order to get adequate air flow into the cylinder, the inlet valve need enough opening with bigger diameter because over come air flow restriction, reduce the intake air heat, allow excess air for complete the combustion to increase the volumetric efficiency and scavenging effect.

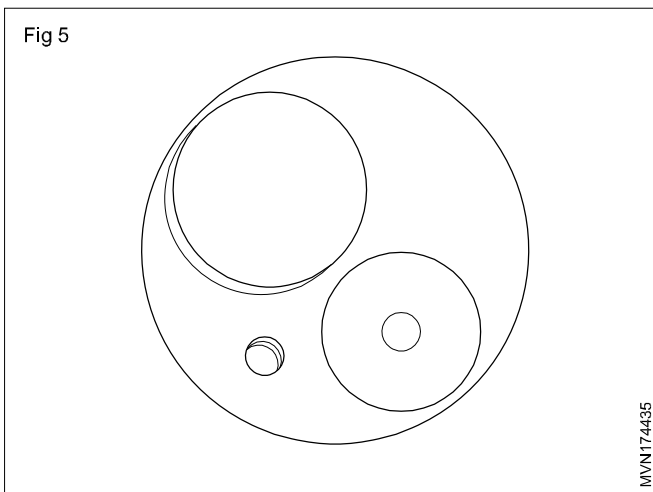

**Valve timing**

Each manufacturer specifies the timings of the opening and closing of the valves as per the design of the engine to give the maximum output under all loads and speeds.

The opening and closing of the valves in an IC engine in relation to the movement of the piston and flywheel is called valve timing. Fig 6

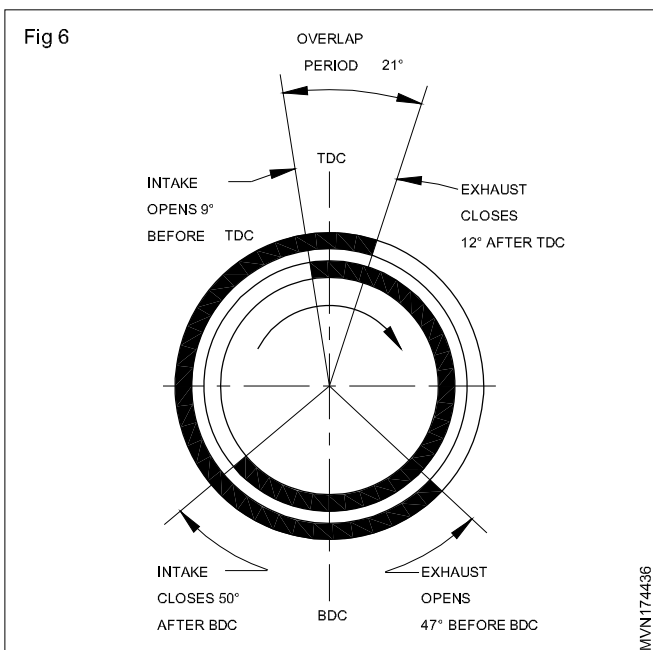

The opening and closing of the valves exactly at TDC & BDC do not improve the volumetric efficiency of an engine. Burnt gases also are not driven out fully.

Practically, the valves are arranged to open early and close late to fill the cylinder fully and to allow all burnt gases to escape from the cylinder.

**Inlet valve**

**Lead**

Inlet valves are made to open certain degrees earlier than T.D.C. This enables air fuel mixture to fill the cylinder to its capacity. It also helps in scavenging burnt gases by using the momentum of intake air/air fuel mixture.

**Lag**

Inlet valves are made to close certain degrees after B.D.C. to increase the volumetric efficiency by allowing more charge.

**Exhaust valve - Lead**

Exhaust valves are made to open certain degrees earlier than B.D.C.

**Lag** - Exhaust valves are made to close certain degrees after T.D.C. to develop a suction effect by the outgoing gases. It also helps in the scavenging of the exhaust gases by using the intake charge's momentum.

**Overlap period** - At the end of the exhaust stroke and the beginning of the suction stroke, both the valves remain open for certain degrees. This period during which both the valves remain open is called the valve overlap.

**Graphical representation of valve timing**

The valve timing is represented by a diagram drawn on the face of the flywheel in degrees of the crankshaft rotation.

**Valve timing (Jeep)**

- Inlet valve open 9 degrees before T.D.C.
- Inlet valve closes 50 degrees after B.D.C.
- Exhaust valve opens 47 degrees before B.D.C.
- Exhaust valve closes 12 degrees after T.D.C.
- Over lap period 21 degrees

Valve timing varies from one make of engine to another valves are exposed to various chemical, mechanical and thermal stresses during operation. They must maintain their basic shape and dimensions throughout the expected life of the engine. In addition, the integrity of the sealing surface of the valve and mating valve seat is critical to durability and performance. Engineers determine the valve material, shape, specifications, and surface coatings to match the specifications engine family, expected operating environment, and projected length of service. Valves commonly used in small engines are classified as one-piece, projection-tip welded, or two-piece-stem welded-stem valves.

**Variable Valve Timing (VVT) (Fig.7)**

Variable-valve (VVT) technology, became standard in engine design, variable valve timing becomes the next step to enhance engine output.

The valves activate the breathing of engine. The timing of breathing, that is, the timing of air intake and exhaust, is controlled by the shape and phase angle of cams. To optimise the breathing, engine requires different valve timing at different speed. When the valve increases, the duration of in take and exhaust stroke decreases so that fresh air becomes not fast enough to enter the combustion chamber, while the exhaust becomes not fast enough to leave the combustion chamber. Therefore, the best solution is to open the inlet valves earlier and close the exhaust valves later. In other words, the overlapping between intake period and exhaust period should be increased as revolution increases.

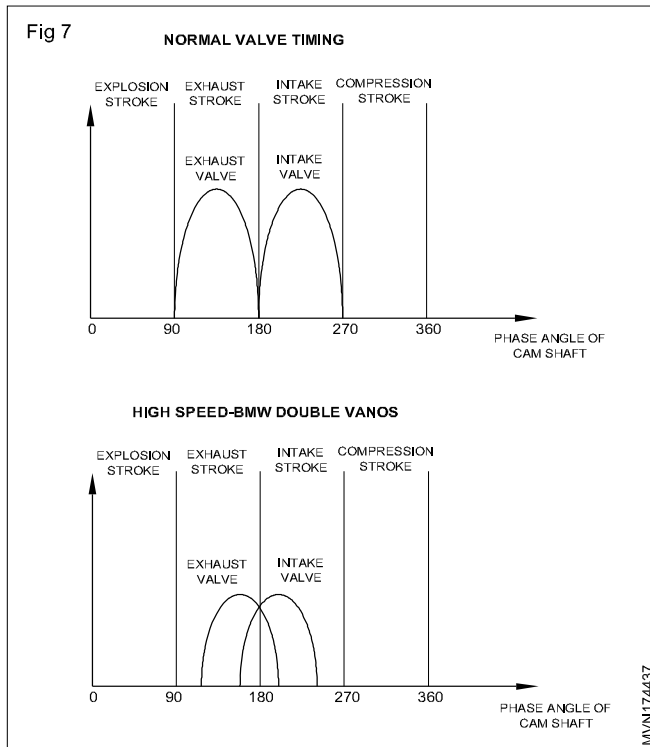

With variable valve timing, power and torque can be optimised across a wide rpm band. The most noticeable results are:

- The engine rpm higher, thus raises peak power. For example, Nissan's 2-litre neo VVI engine output 25% more peak power than its non-VVT version
- Low-speed torque increases, thus improves drivability. For example, Fiat barchetta's 1.8 VVT engine provides 90% peak torque between 2,000 and 6,000 rpm.

Moreover, all these benefits come without any drawback.

### Variable lift

In some designs, valve lift can also be varied according to engine speed. At high speed higher lift quickness air intake and exhaust, thus further optimise the breathing. Of course, at lower speed such lift will generate counter effects like deteriorating the mixing process of fuel and air, thus decrease output even leads to misfire. Therefore the lift should be variable according to engine speed.

### Cam-changing VVT

Many automobile engine's are used VVT in the late 80s by launching its famous VTEC system (Valve timing electronic control).

It has 2 sets of cams having different shapes to enable different timing and lift. One set operates during normal speed, say, below 4,500 rpm. Another substitutes at high speed.

However, cam-changing system remains to be the most powerful VVT, since no other system can vary the Lift of valve as it does.

Ex. Honda's 3-stage VTEC

### Cam-phasing VVT

Cam-phasing VVT is commonly used mechanism and it varies the valve timing by shifting the phase angle of camshafts. For example, at high speed, the inlet camshaft will be rotated in advance by 30° so to enable earlier intake. This movement is controlled by engine management system according to need, and actuated by hydraulic valve gear.

## Camshaft

**Objectives:** At the end of this lesson you shall be able to

- state the function of the camshaft
- state the constructional features and material of the camshaft.

### Functions of the camshaft

The camshaft is used to convert the rotary motion into reciprocating motion with the help of the cam lobe. This reciprocating motion is transmitted to the valve through the tappet, push-rod and rocker levers. The camshaft is driven by crank shaft and it rotates half the speed crankshaft. The camshaft also drives the oil pump shaft. In petrol engines the fuel pump and the distributor get their drive from the camshaft.

### Construction of the camshaft

The camshaft (2) (Fig 1) is either forged or cast with the cam lobes (1) one for each valve. The camshaft has a series of support bearings along its length.

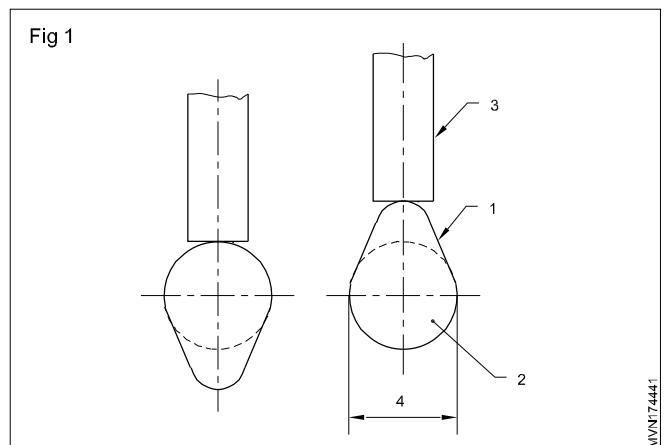

The cam surface (Fig 2) is hardened for longer life. In some engines the axis of the tappet/lifter (3) is slightly offset from the axis of the cam lobe (1). This offset gives a little rotation to tappet/lifter, when it moves up. So the bottom of the tappet/lifter (3) wears out uniformly. The lifter/tappet (3) rests on the cam lobe (1). The lifter (3) remains in its position on the base circle (4). When the cam rotates the lobe lifts the lifter (3).

### Material for camshaft

Forged alloy steel

## Camshaft drive mechanisms

**Objective:** At the end of this lesson you shall be able to

- state the different types of camshaft drive mechanisms.

The camshaft gets the drive from the crankshaft and rotates at half the crankshaft speed, since each valve opens once in every two revolutions of the crankshaft. There are three types of camshaft drive mechanisms.

- Gear drive (Fig.1)
- Chain drive (Fig.2)
- Belt drive (Fig.3)

### Gear drive

This direct drive (Fig.1) P No 58 is used where the crankshaft and the camshaft are very close to each other. Since the r.p.m. of the camshaft is half of the crankshaft speed, the camshaft gear (1) teeth is twice as many as the crankshaft gear (2) teeth. In this, the engine's camshaft rotates in the reverse direction of the crankshaft. In some engines an idler gear is used to have the same direction of rotation for the crankshaft and the camshaft.

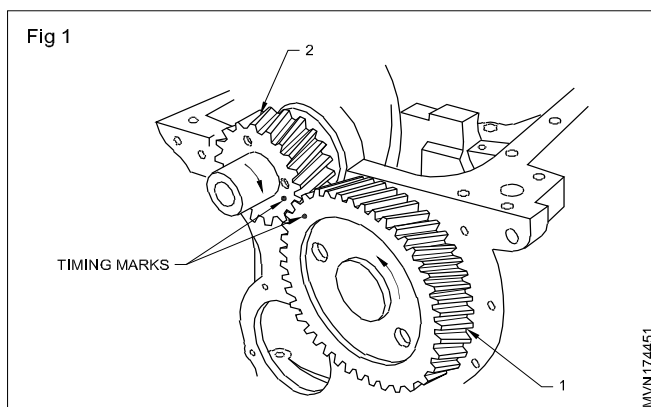

### Chain drive

The timing gear sprockets (Fig 2) are driven by a chain (1). Hence this drive is called a sprocket drive. The direction of rotation of the crankshaft and camshaft is the same. It is used when the distance between the crankshaft and the camshaft is more. No idler gear is used in the chain drive.

### Belt drive

This drive (Fig 3) is similar to a chain drive. Instead of a chain a belt (2) is used to drive the camshaft. The belt drive

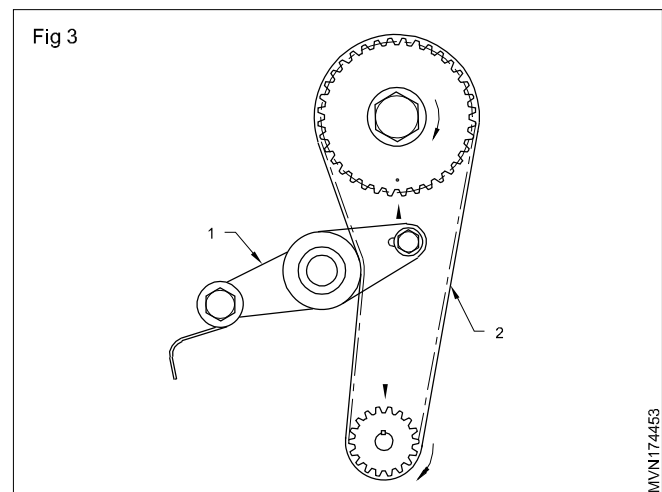
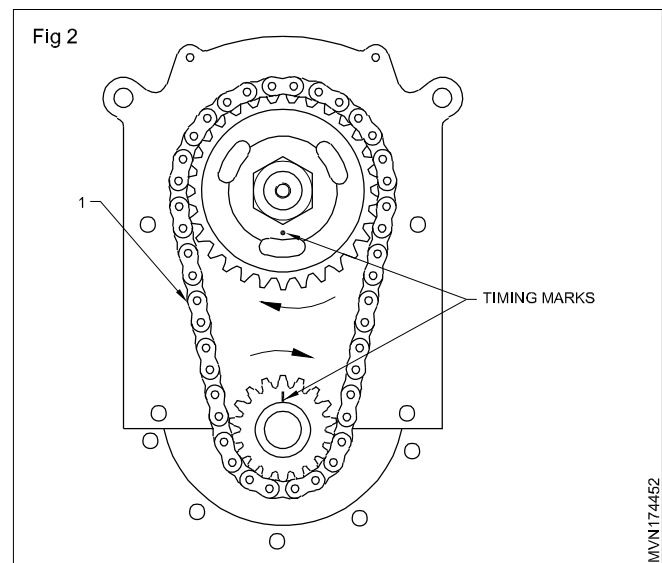
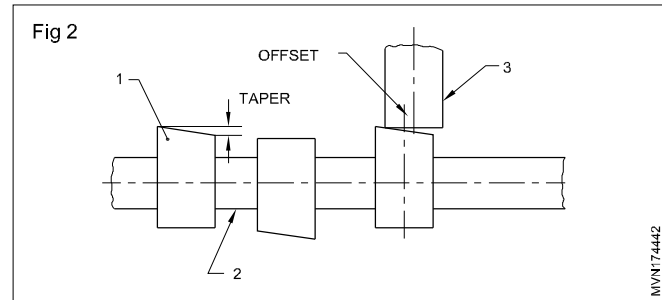

is mostly used in overhead camshaft design. The direction of rotation of the camshaft and crankshaft is the same. An automatic belt tensioner (1) is used to avoid slipping of the belt.

### Cam shaft classification

Cam shaft are classified based on its location and number of shafts



- 1 Bottom mounted traditional camshaft (OHV) - (Fig.4) and single over head valve (SOHV) - (Fig.5)
- 2 Single over head cam shat. (Fig.6)
- 3 Double over head cam shaft (DOHC) (Fig.7)

The main disadvantages of an OHV design is that it's difficult to control precisely the valve timing at high rpm.

Advantages of an OHV engine include lower cost, proven durability, low-end torque and compact size. OHV design is better suited for slow speed engines. In heavy duty engines offers higher torque at lower rpms. (Fig.4)

**Bottom mounted traditional cam shaft (OHV Engine) (Fig 4) & SOHV (Fig.5)**

OHV in general means over head or valves are fitted in the cylinder head. Often the term "OHV is used to describe the engine design where the camshaft is fitted inside the engine block and valves are operated through lifters, pushrods and rocker arms. This design is also known as a "Pushrod" engine. The OHV design has been successfully used for decades.

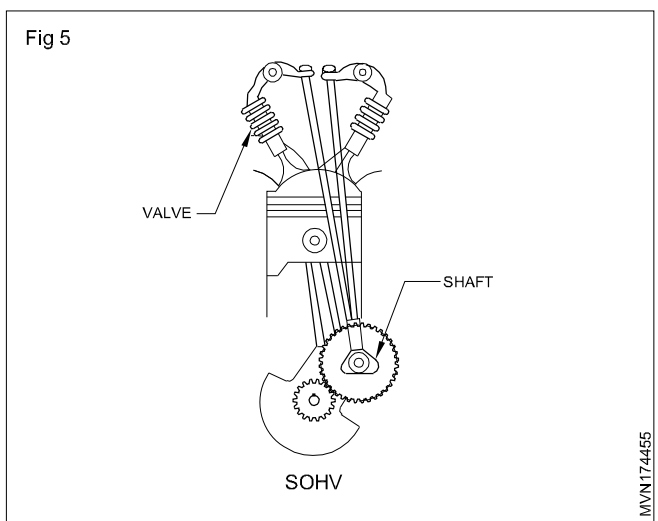
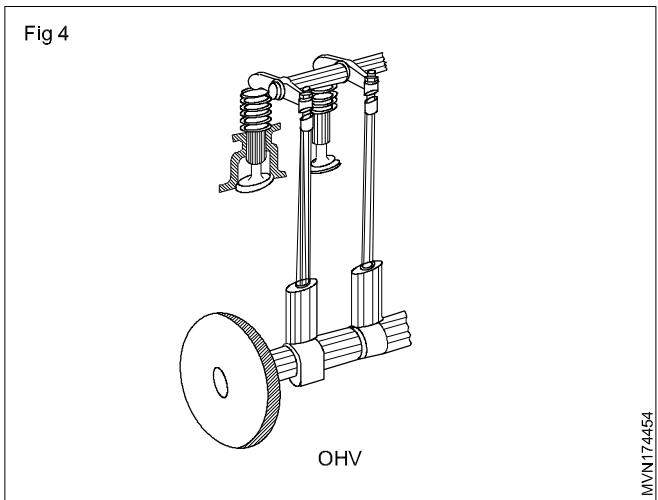

**Over head cam/single over head cam shaft (OHC/ SOHC)(Fig.6)**

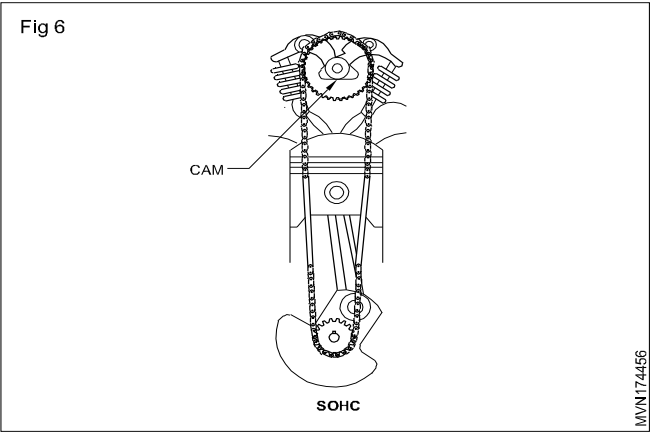

OHC means over head cam in general, while SOHC means single over head cam or single cam. In SOHC engine the camshaft is installed in the cylinder head and valves are operated either by the rocker arms or directly through the lifters.

The main advantage of an OHC design is that valves are operated almost directly by the camshaft, which makes it easier to maintain precise timing at higher rpms. It's also possible to install three or four valves per cylinder.

**Double over head cam shaft (DOHC) (Fig.7)**

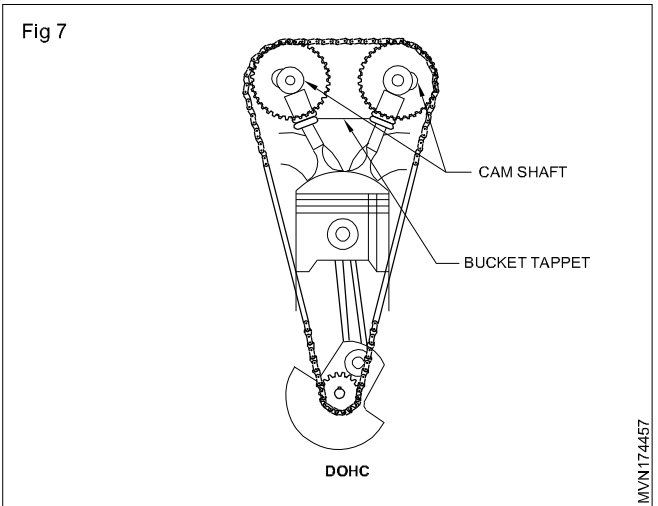

DOHC means double over head cam. Most modern vehicles have DOHC engines. DOHC engine has two camshafts and 4 valves per cylinder. One camshaft operates intake, while another camshaft operates exhaust valves. This allows the intake valves to be at a larger angle from the exhaust valves, so the volumetric efficiency increases and produces more horse power out of smaller engine volume.

The main advantage of the DOHC design allow technologies like direct injection, variable valve timing and variable valve lift can be easily implemented in a DOHC engine, further improving fuel efficiency.

The main disadvantage of the DOHC technology includes a larger size and more complex design with additional timing belt or chain components. A timing belt needs to be replaced at recommended intervals, adding to maintenance costs.