

**Description and constructional feature of cylinder head**

- Objectives:** At the end of this lesson you shall be able to
- state the constructional features of the cylinder head
  - state the importance of cylinder head design.

**Cylinder head (Fig 1)**

The cylinder head is made of a single casting. It is bolted on the top of the cylinder block. It has passages for oil and water circulation. It accommodates valves, spark plugs/injectors (in the case of diesel engines) and heater plug. A combustion chamber is also provided in some cylinder heads. In the case of the overhead valve system, the cylinder head supports the rocker shaft assembly.

The lower surface of the cylinder head is machined to the specified accuracy and a gasket is used in between the cylinder head and cylinder block to avoid leakage.

The head also provided spaces for the passages that feed air, water fuel to the cylinder and that allow the exhaust to escape.

Material: Cast iron, aluminium alloy.

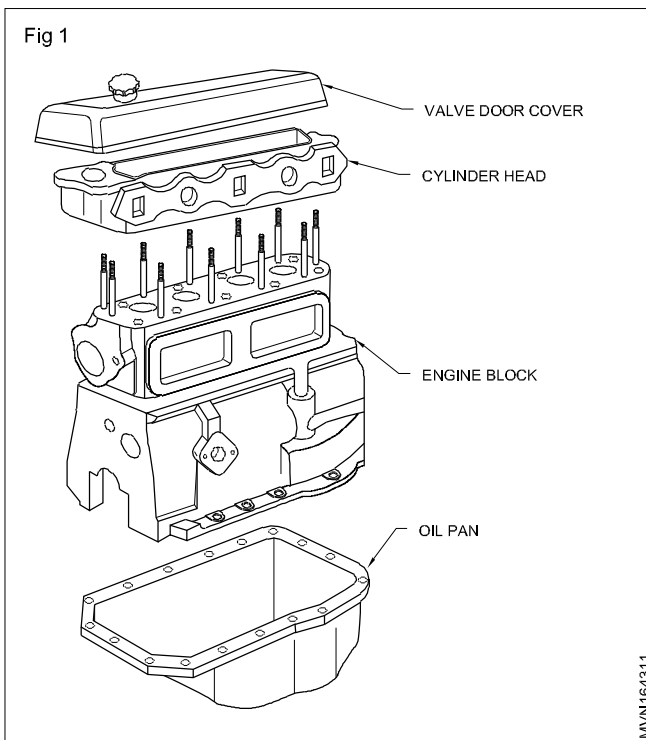

**Types of cylinder heads**

Four types of cylinder heads are used in an automobile engine as per the valve arrangements.

They are as follows.

- 'L' head (Fig.2)
- 'I' head (Fig.3)
- 'F' head (Fig.4)
- 'T' head (Fig.5)

**'L' head**

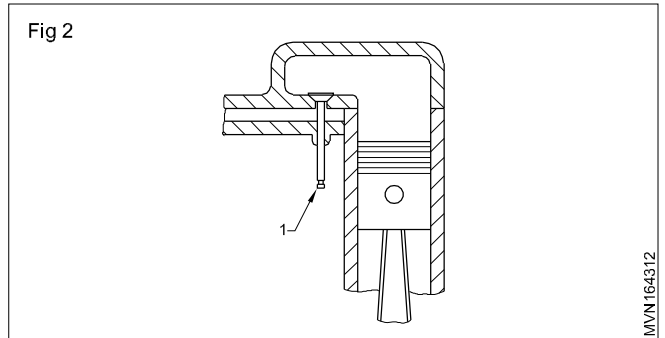

In the 'L' head, the inlet and exhaust valves (1) are located on one side of the cylinder block and the valves are operated by a single camshaft through the tappet directly. (Eg. Dodge)

**'I' head**

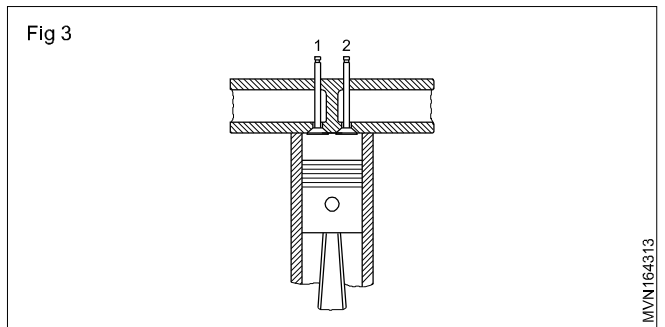

In the 'I' head the inlet (1) and exhaust valves (2) are located on one side of the cylinder head. The valves are operated by a single camshaft through the tappet, push-rod and rocker arm mechanism. (Eg. Ambassador, Ashok Leyland).

**'F' head**

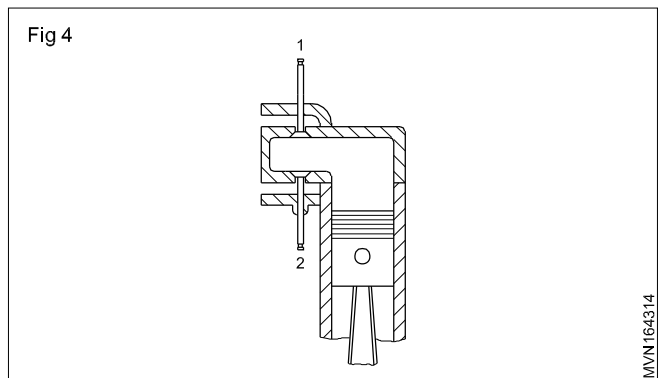

In the 'F' head, the inlet valves (1) are located on one side of the cylinder head and the exhaust valves (2) are located on the other side of the cylinder block. The valves are operated by a single camshaft.

The inlet valves are operated by the tappet, push-rod and rocker arm mechanism. The exhaust valves are operated by the tappet directly. (Eg. Mahindra & Mahindra jeep)

### 'T' head

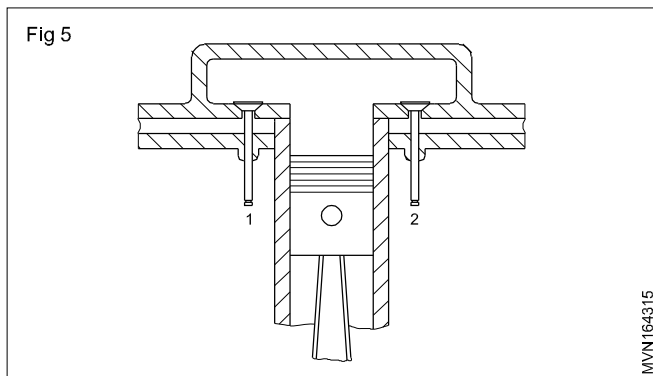

In the 'T' head, inlet valves (1) are located on one side of the cylinder block and the exhaust valves (2) are located on the other side of the cylinder block. Two camshafts are used to operate the valves, one for inlet and the other for exhaust. The valves are operated by the tappet directly. (Eg. Ford)

In thick fuel is injected into the combustion chamber against high compressions pressure in the combustion chamber of the C.I. engine cylinder. The combustion depends upon the following factor.

- Fine atomization
- High temperature for quick ignition
- High relative velocity between air and fuel particles
- Good mixing of air and fuel particles.

Atomization, penetration and spreading of fuel depends on injection system, cylinder bore and stroke, compression ratio and cooling system is determine operating temperature. Fuel mixing depends upon air intake system, injection pattern and combustion chamber design.

**The design of combustion chamber plays an important part in the combustion process.** In diesel engines, the following types of combustion chambers have been used.

- a Open combustion chambers (Fig 6)
- b Turbulence chambers (Fig 7)
- c Precombustion chamber (Fig 8)
- d Air cells (Fig 9)
- e Energy cells (Fig 10)

**a Open combustion chambers (Fig.6):** An open type of chamber is that in which all the air is contained in a single space at the time of injection. It is the simplest form of combustion chamber in which the injection nozzle sprays fuel direct into the combustion chamber. This arrangement is known as open system or direct injection system.

In this type of chamber, the fuel motion is greater than air upon which the nature of combustion largely depends. In order to bring fuel and air together, the flat head piston has been replaced by concave head piston in modern engines.

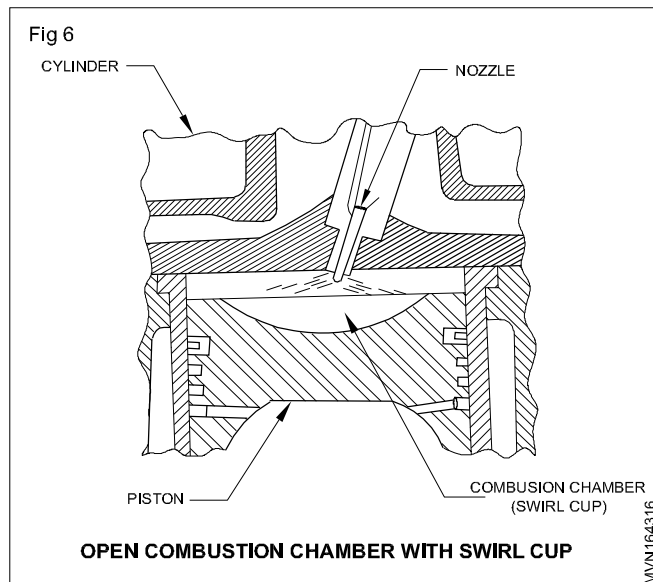

The deep cut-out swirl cup on the piston crown is being widely used.

Open system combustion chambers are widely used in medium and large-bore engines operating at low and medium speeds.

**b Turbulence chambers (Fig.7):** In this type of chamber, the fuel is injected into an auxiliary chamber known as turbulence chamber with the cylinder by an orifice. The auxiliary chamber houses almost full charge at the end of compression and is nearly spherical in shape. The piston forces air charge into the turbulence chamber and sets up a rapid rotary motion. As the piston rises up, the velocity of air increases through the throat of orifice and reaches at the peak some waht before T.D.C. Near T.D.C. the injector nozzle injects fuel into the turbulent air currents which results in good mixing during combustion.

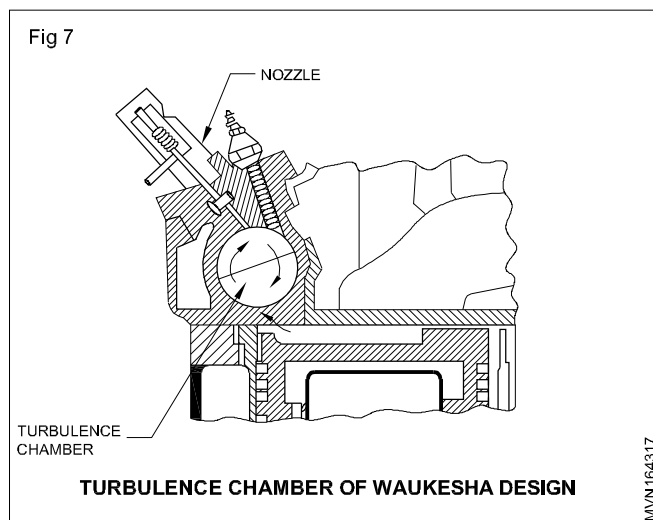

**C Precombustion chamber (Fig.8):** This chamber is located at the cylinder head and is connected to the engine cylinder by small holes. It occupies 40% of the total cylinder volume. During the compression stroke, air from the main cylinder enters the precombustion chamber. At this moment, fuel is injected into the precombustion chamber and combustion begins.

Fig 8

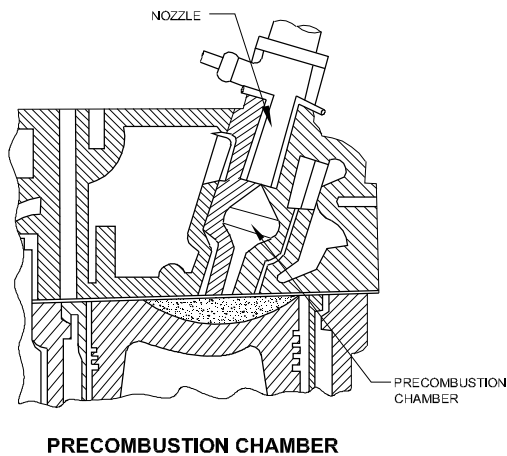

Pressure increases and the fuel droplets are forced through the small holes into the main cylinder, resulting in a very good mix of the fuel and air. The bulk of the combustion actually takes place in the main cylinder. This type of combustion chamber has multi-fuel capability because the temperature of the prechamber vaporizes the fuel before the main combustion event occurs.

- d Air cells (Fig.9):** Combustion chamber an air cell is a space provided in the cylinder head or piston crown in which a large part of air is trapped during compression. In air cell systems, the injector nozzle sprays fuel direct into the main chamber where combustion takes place.

Fig 9

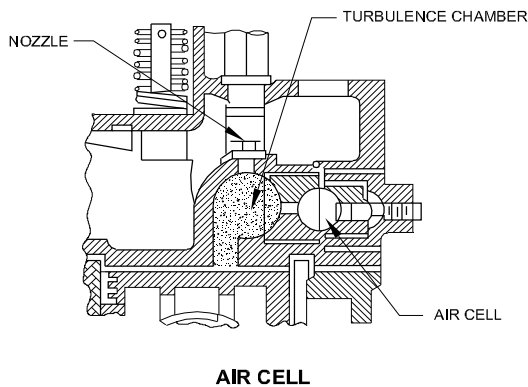

When the piston moves down on its working or power stroke, air pressure is at its maximum in the cell and pressure in the main combustion chamber starts to fall down. The higher pressure in the air cell causes its air to expand and blow out into the main chamber. Thus an additional turbulence is created and complete combustion of fuel charge is ensured.

As a portion of air remains trapped without combustion in the cell so in improved designs, air cell is used in combination with turbulence or precombustion chamber to obtain better performance.

- e Energy cells (Fig.10):** The difference between air cell and energy cell is that fuel is blown into the energy cell where it burns using air in the cell. In air cell system, the cell simply stores and given up an air charge. The combustion in the energy cell creates a high pressure and grater turbulence and leaves no idle air in the cell.

Fig 10

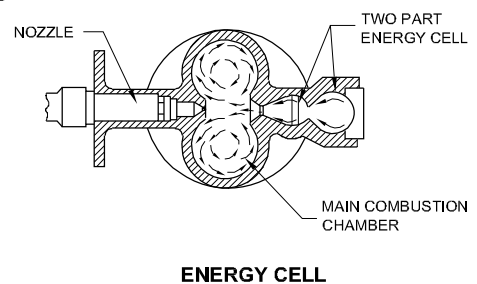

The energy cell system consists of two rounded spaces cast in the cylinder head. The intake and exhaust valves open into the main combustion chamber. The horizontal the nozzle sprays fuel across the main chamber in the direction of energy cell mouth. While the fuel charge is passing across the centre of main chamber, nearabout half the fuel mixes with hot air and burns at once. The remaining fuel enters the energy cell and starts to burn there. At this point, the cell pressure rises rapidly, tending the combustion products to flow back into the main combustion chamber at a high velocity. As a result of this, a sharp swirling movement of fuel and air is set up in each lobe of main chamber, promoting final mixing of fuel and air and ensuring complete combustion. The two restricted openings of energy cell control the time and rate of expulsion of blast from energy cell into main combustion chamber.

The energy-cell combustion systems fulfil the requirements of high speed engines and give high power output without high excessive pressures in the main combustion chamber.

## Effect on size of intake and exhaust passages

**Objectives:** At the end of this lesson you shall be able to

- state the effect and size of intake of exhaust passages
- importance of cylinder head gasket
- types of cylinder head gasket materials.

**Inlet valve:** Is too larger than exhaust valve. Because they want to fill more quantity of Air/Fuel mixture (petrol) or Air (Diesel) in the combustion chamber to regulate the engine efficiency. Because engine efficiency depends upon Volumetric efficiency of an combustion chamber (Fig 1).

There are two reasons behind the inlet valve larger than exhaust valve. One main reason is to increase the volumetric efficiency of an engine. Another one is acting pressure behind the inlet valve. Exhaust gas pressure only react to the face portion of the valve. But in an inlet valve, the inlet

air pressure are reacted to the behind/Rear portion the inlet valve face & larger face can withstand this pressure without any damage. For that reason the inlet valve face is designed to larger size than exhaust valve.

The main reason for the size difference is to avoid preignition and knocking.

**Cylinder head gaskets:** It Form the most critical seal on an engine - between the cylinder head and the engine block deck. (Fig.1)

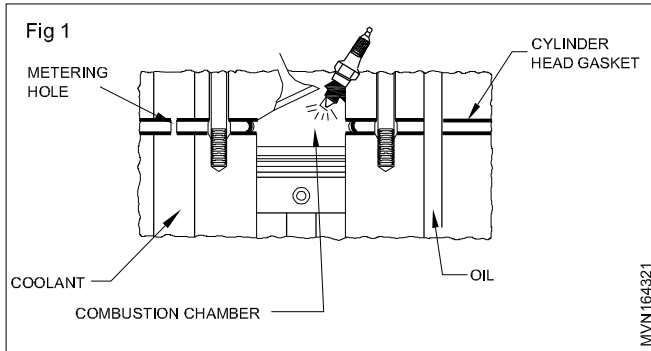

The head gasket must seal the combustion, pressures up to 1,000 psi (689.5 kPa) in gasoline engines and 2,700 psi (1,862 kPa) in turbocharged diesel engines. In addition, the head gasket must withstand combustion temperatures that are in excess of 2,000°F (1,100°C).

The head gasket also must seal coolant and hot, thin oil flowing under pressure between the block and head. Modern coolant formulas and oil detergents and additives tend to cling to surfaces and soak into gaskets. Gaskets materials must be chosen carefully to resist these fluids and maintain an effective seal. many head gasket coolant holes also meter the coolant flow to ensure proper circulation.

Head gaskets must resist the forces that tend to scuff gasket surfaces and inhibit proper sealing. One factor is engine vibration and head shifting and flexing that result from combustion pressures.

Another factor is the differing expansion rates of bi-metal (aluminum head and cast iron block) engines. Aluminum expands about twice as much as cast iron . The uneven expansion rates create a shearing action that the head gasket must accommodate.

Head gaskets also must resist crushing from cylinder claiming forces that may be unevenly distributed across the head. These claiming forces run as high 200,000 lbs (90,800 kg).

The following materials are used in cylinder head gasket

- 1 Copper - as-bestos gasket
- 2 Steel - as-bestos - copper gasket
- 3 Steel - as-bestos gasket
- 4 Single steel ridged gasket

### Importance of turbulence

Turbulent flow in an engine plays an important role in determining the combustion efficiency. It improves the thermal efficiency of engine, reduce the knocking, reduces NOX emission, oxidized carbon, hydrogen and other combustible elements. Turbulence ensure a thorough mixing of the air and fuel which ensures that fuel is quickly burnt and releasing the complete energy.