

Alternator

- Objectives :** At the end of this lesson you shall be able to
- explain the purpose of an alternator
 - describe the circuit of the alternator
 - list out the different parts of the alternator
 - explain the functions of the various parts of an alternator
 - explain the working of an alternator.

Purpose of alternator (Fig 1)

Right from the beginning, vehicles were fitted with dynamos for producing electricity. In present day vehicles the number of electrical accessories used has increased. Thus the demand for higher capacity generators has arisen. This can only be met by increasing the capacity of the generator and also by running it at higher speeds.

The vehicles in large cities have to, often, move at very slow speeds due to heavy traffic. Normally a DC dynamo will not be able to charge the battery at such low speeds. The speed of the dynamo cannot be increased beyond a certain limit. Therefore, an alternator or AC generator is used. An alternator can produce more electricity at low r.p.m.

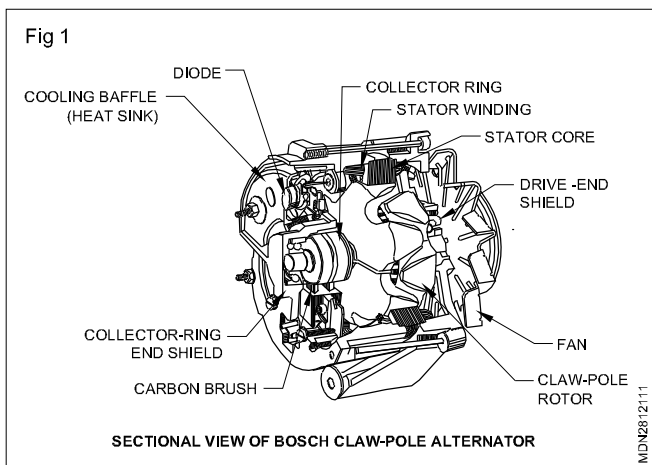

Alternator wiring circuit in a vehicle (Fig 2)

The alternator's (1) output terminal (3) is connected to the 'A' terminal (2) of the voltage regulator. The alternator's (1) field terminal (5) is connected to the 'F' terminal of the voltage regulator (4). The 'B' terminal of the regulator is connected to the battery (8) via the ammeter (9). The battery's (8) connection is also connected to the 'A' terminal (2) of the regulator (4) via the ignition switch (11) and indicator lamp (10). The terminal I (6) of the voltage regulator (4) is connected to the Ignition terminal (SW).

Description of parts of an alternator

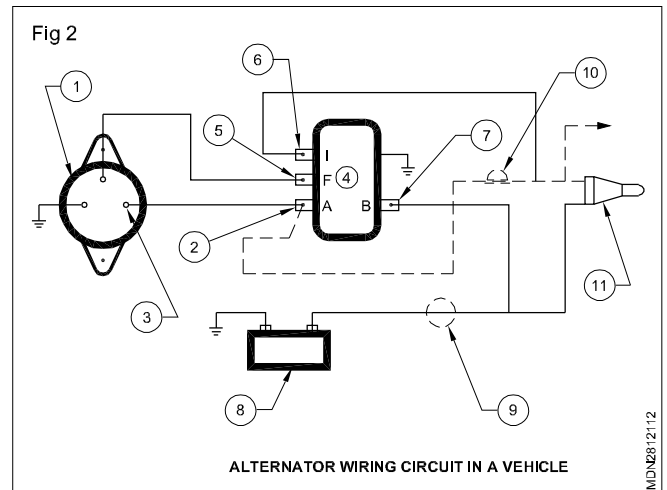

Drive end frame (Fig 3)

The drive end frame supports a pre-lubricated sealed bearing in which the drive end of rotor shaft rotates.

The rotor and its shaft is mounted and encased between drive end frame and slip ring end frame.

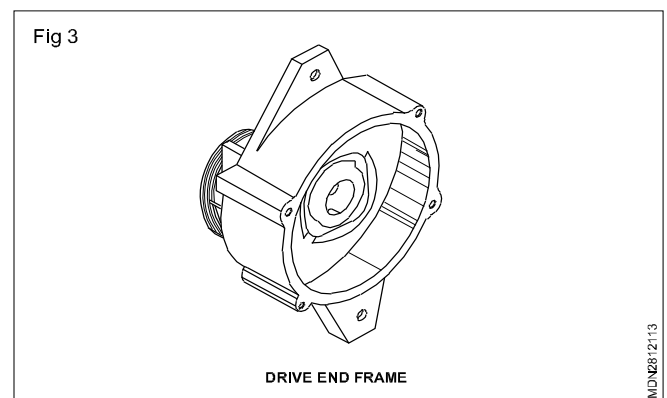

The rotor assembly (Fig 4)

This consists of a steel shaft which carries the driving pulley and cooling fan, a cylindrical iron core, and two insulated slip rings. A large number of turns of insulated wire are wound over the core to form the field winding.

Each end of the winding is connected to its own slip ring and spring-loaded brush. The winding is enclosed by two iron pole pieces with eight interlocking fingers which become alternate north and south poles when direct current is passed through the winding via the brushes.

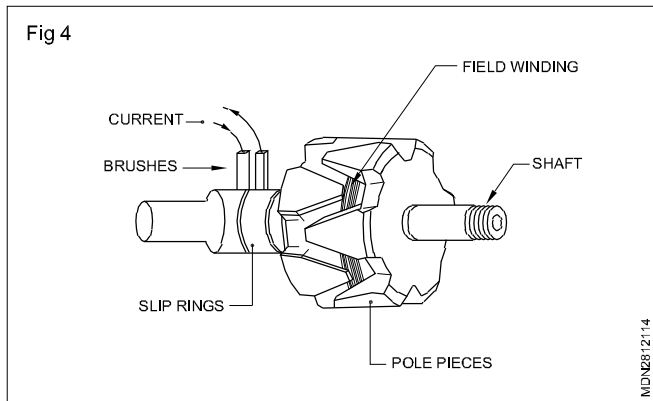

Stator assembly (Fig 5)

It is a stationary part which is held between two end covers. (Figs 1 & 5)

This consists of a laminated, cylindrical, iron core which is slotted to permit the fitting of three sets of insulated windings. In the lighter units these windings are star connected and in the heavier units delta connected. The number of coils depends on the number of poles.

The 'N' pole and 'S' pole of the magnet pass each stator winding and due to interruption of the magnetic flux the current is generated in the stator windings.

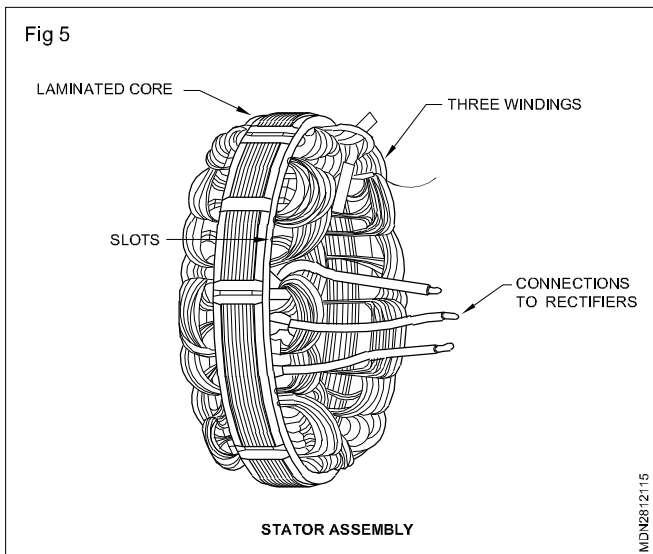

Diodes

The diodes are made of silicon and these allow current to flow in one direction only. They are so connected as to allow the current to flow from the alternator to the battery but not in the opposite direction.

Three diodes on the negative side are connected to the rear end housing and three diodes on the positive side are mounted on an insulated heat sink.

The diodes convert the AC produced by the alternator to DC since the automobile accessories are designed to utilise DC current.

Slip ring end frame (Fig 6)

The slip ring end frame supports the rectifier mounting plates and a pre-lubricated bearing for rotor/shaft rotation. The rectifiers are pressed into the slip ring end head or heat sink and are connected to the stator leads.

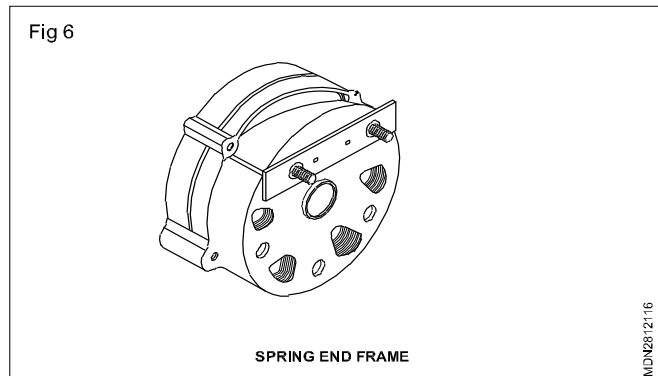

Electronic regulator (Fig 7 & 8)

To protect the battery and the accessories against high voltage, the alternator voltage must be controlled. This is done by using a voltage regulator which varies the current flow to the rotating field (rotor). The regulator work is done by electronically.

A transistor regulator consists primarily of resistors, capacitors (condensers), diodes and transistors. It is a complete static unit which controls the alternator voltage. It is durable and efficient. It safely allows a high field-current flow, and it has a longer service life than the vibrating contact regulator. An equally important feature is the ease with which it can be tested, adjusted and serviced.

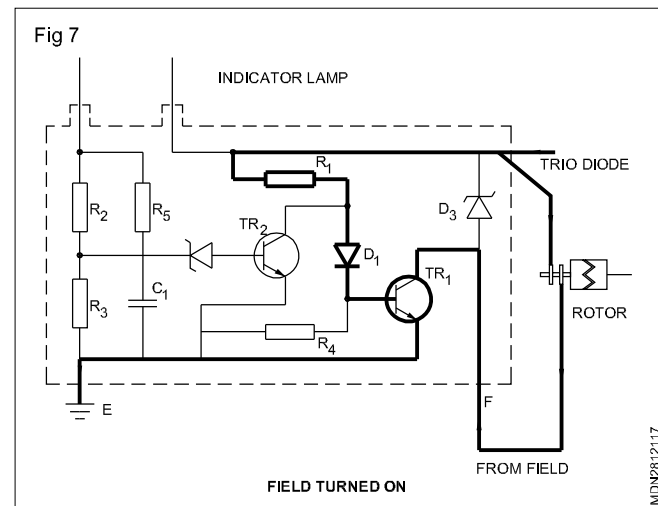

When the permanently magnetized rotor rotates, an alternating voltage is induced in the stator winding which is rectified by the three negative and three positive diodes and DC current flows into the battery. The rectified current of each phase winding also flows over diodes D1, D2, D3 into the regulator to resistor R1, to the collector of resistor TR3 and to the resistor R3 to ground. The transistor TR3 is not switched on because the low voltage allows zener diode D6 and diode D5 to block the base circuit. However, transistors TR2 and TR1 are switched on because current can now flow over both emitter bases to ground.

With both transistors switched on, current from the output terminal of the alternator supplies current to the regulator over resistor R5 to the field coil and transistor TR1 (collector elements) to ground. Output current also flows from resistor R5 to resistors R2 and R4 to ground. As charging voltage increases, the voltage impressed across resistor R4 is also impressed across diode D5 and zener diode D6.

When the breakdown voltage is reached, transistor TR3 switches on because the emitter-base circuit ground is completed. This causes TR2 and TR1 to shut off since current now flows over the lower resistance circuit from resistor R1, transistor TR3 (collector-emitter) to ground, robbing the current flow from transistor TR2. The field current flow stops. As system voltage decreases, diodes D5 and D6 stop conducting current and transistor TR3 shuts off. This cycle repeats many times per second to maintain present alternator voltage. The capacitors C1, C2 and C3 and diode D4 perform the same function.

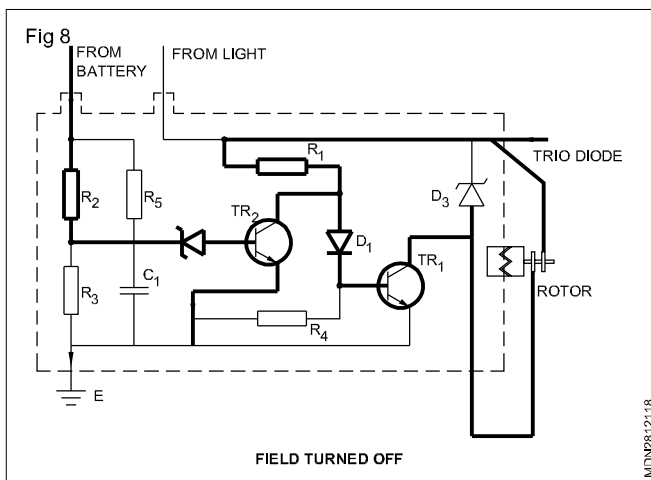

Operation of alternator (Fig 8)

When the engine is started, the belt drives the rotor (3) assembly.

During rotation the 'S' poles and 'N' poles of the rotor magnet pass through each stator coil (4).

Due to this rotation of the rotor assembly the current is generated in the stator coil (4), alternatively positive and negative.

If more rotor magnets pass through each stator coil (4) in a given time, the generation of current will be more, since they form the ends of metal fingers, each finger acting like a magnet. These fingers interlock but do not touch each other.

The current produced is allowed to pass through silicon diodes (5) mounted on the heat sink (6). The diodes convert the AC to DC.

The heat produced in the diodes is dissipated by the heat sink.

The current passes through the battery terminal (7), the ammeter (8) and to the battery (1) for charging.

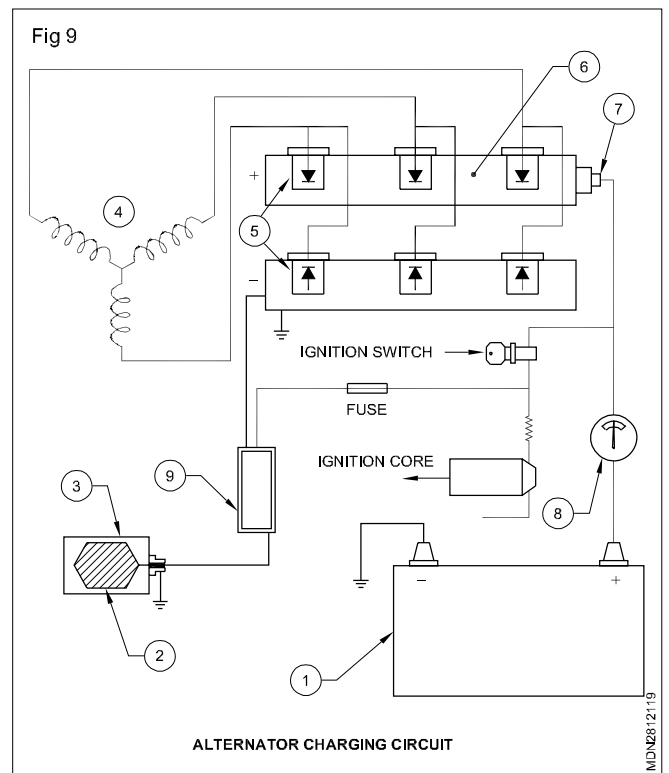

Differences Between Alternator And Dynamo

Objectives : At the end of this lesson you shall be able to

- list out the differences between an alternator and a dynamo
- state the precautions to be followed while using alternators
- state the common troubles and their remedies in alternators.

DIFFERENCES BETWEEN ALTERNATOR AND DC GENERATOR/DYNAMO

Alternator	DC Generator/Dynamo
1 The alternator develops DC current	The generator also develops AC.
2 It produces enough current during idling speeds of the engine (18 to 20 amps).	It produces very little current during idling. (No charging of battery is possible.)
3 No cut out is required in the charging circuit as diodes do not allow return current.	Cut out relay is used in the charging circuit.
4 For the same output the weight of the alternator is less. Ex.12 V - 8 kg	But the weight of the generator is more. Ex.12 V - 12 kg
5 The alternator limits its own current. No current regulator is used.	The generator does not limit its own current. Hence a current regulator is required.
6 Diode rectifiers do not pass the current in the reverse direction.	In the generator charging circuit a cut out relay acts as a reverse current relay.
7 In the alternator the voltage is only to be regulated. regulated to a certain value.	In the generator both voltage and current are to be
8 Alternator can run up to a very high speeds (say 20,000 r.p.m.).	Generator r.p.m. is limited to 9000.
9 Less maintenance due to use of slip ring and brushes.	Frequent maintenance due to use of commutator and carbon bushes.
10 The alternator charges the battery at low engine speeds (Idling r.p.m.).	The generator does not charge the battery at low idle speeds.
11 It has high output weight ratio.	It has low output-weight ratio.
12 The alternator is simple and robust in construction, looks compact.	The generator is not very robust.
13 Due to transformation of mechanical energy to electrical energy, the alternator works with 50% efficiency only.	In the generator transfer losses are very minimum and its efficiency of working is very high.
14 The alternator uses diode rectifiers to rectify AC into DC for charging the battery.	The generator uses commutator and brushes to do the rectification of AC to DC.

Precautions to be followed while handling alternators

- Ensure all connections are tight and clean.
- Ensure that there is no open circuit in the charging circuit.
- Observe correct polarity when refitting battery in the vehicle. Reversed battery connections may damage the rectifier and the vehicle wiring.
- Do not short or ground any of the terminals of the alternator or regulator.
- Do not allow water to seep into the alternator.
- Do not operate the alternator unless it is connected to a load.
- Disconnect the battery, alternator and regulator before carrying out any arc welding on the vehicle.
- The alternator should not be mounted near the exhaust manifold without suitable heat protection.
- Do not attempt to polarise the alternator.
- The field circuit must never be grounded on this system between the alternator and the regulator.
- Maintain belt tension.

Common troubles and remedies in alternator

Objectives : At the end of this lesson you shall be able to

- state the causes and their remedies for no charge when engine is running
- state the causes and their remedies for low output voltage
- state the causes and their remedies for excessive output (charging at high rate)
- state the causes and their remedies for noisy alternator.

	Trouble	Causes	Remedy
1	No charge when engine is running.	Blown fuse wire in regulator. Drive belt loose. Broken drive belts. Worn out or sticky brush. Open field circuit. Open charging circuit. Open circuit in stator winding. Open rectifier circuit. Defective diodes. Worn or dirty slip rings. Loose connections.	Locate cause and rectify and then replace fuse. Adjust belt tension. Replace. Rectify. Replace. Rectify. Rectify. Rectify. Rectify. Replace. Replace. Tighten.

Starting motor circuit and constructional details

Objectives : At the end of this lesson you shall be able to

- explain starting circuit
- explain the need of starter motors
- explain the construction of a starter motor
- explain the functions of a starter motor
- explain the functions of a starter drive unit
- explain the need of a solenoid switch
- explain the construction of a solenoid switch
- explain the functions of the solenoid switch.

The starting system is used to start the engine. When the starter switch is pressed/ turned, current flows to the starter motor from the battery and the starter motor's shaft rotates. A drive pinion is connected to the starter motor shaft. The drive pinion turns the engine flywheel till the engine starts.

Description of a starting circuit

The -ve terminal of the battery (1) (Fig 1) is connected to earth. The +ve terminal of the battery (1) is connected to the solenoid switch's (3) battery terminal. From there a wire is connected to the starter switch's (2) input terminal. From the input terminal of the starter switch (2), a wire is connected to the solenoid winding's (7) input terminal. The other end of the winding is connected to earth. From the starter terminal of the solenoid switch a connection is given to the starter motor's (4) input terminal. In a starter motor an internal connection is given to connect the field windings as well as the armature through the brushes and the other end is connected to earth.

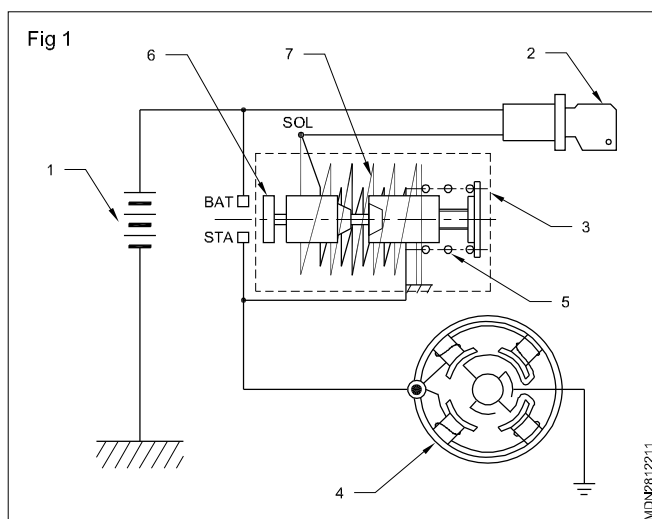

When the key switch is turned, a small amount of current flows from the battery (1) to the starter solenoid (3). This current energizes the solenoid windings and the plunger (6) moves to connect the battery's and starter motor's terminal in the solenoid switch (3).

Current now flows directly to the motor (4). When the switch is released the current flow stops and the return spring (5) pulls the plunger (6) back, disconnecting the starter motor from the battery.

Starter motor

The engine crankshaft must be rotated at a speed of a minimum 100 r.p.m. to start the engine. This action is called engine cranking. As it is hard to rotate the engine at that speed by hand or with a lever, a starter motor is used to crank the engine.

Location of the starter motor

The starter motor is fixed in the rear side of the engine, when the starter is switched on the starter motor's pinion engages with the flywheel ring gear and rotates the flywheel.

Principle

When a current is passed through an armature coil which is placed between two stationary magnets an e.m.f. is induced and the armature coil starts rotating.

Construction

Three kinds of DC starter motors are used.

- Series (Fig 2)
- Shunt
- Compound

In automobiles the series wound type is generally used. In this the field and armature coils are connected in series. This enables the motor to produce a high starting torque. The pole shoes (3), two or four in number, are screwed to the yoke (4) and they have field windings (5). These windings help to produce the magnetic field. The insulation pieces are placed between the pole shoes (3) and metal yoke (4). Copper segments are provided with mica insulation in between the commutator brushes (6).

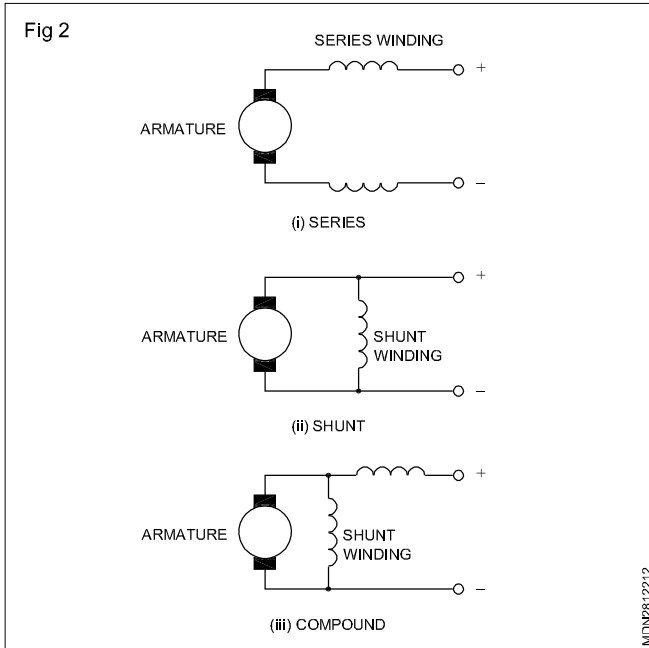

These brushes (6) slide in the brush holders and are kept in contact with the commutator with the help of small springs (8). The brushes (6) are given a curvature at the bottom to have more contact with the commutator (2). The armature is supported either on bushes or coil.

The commutator end is covered by a bracket called commutator end bracket (9). At the drive end, it is covered by the drive end bracket (10). Both the brackets are connected by through bolts (11). At the drive end in the armature shaft, a drive mechanism (12) is fitted.

Operation of starter motor

Current from the battery is supplied to the armature's (1) (Fig 3) coil by two or four stationary brushes (6). These brushes (6) are in contact with the commutator's (2) segments. The same current is also supplied to the field coils (5). Both the field coil (5) and the armature's (1) magnetic field attract and refuse each other and cause the armature to rotate. Each coil of armature (1) is connected to one pair of copper segments of the commutator (2). The brushes come in contact with each coil of the armature (1) by turn, and in the process the armature's speed increases further.

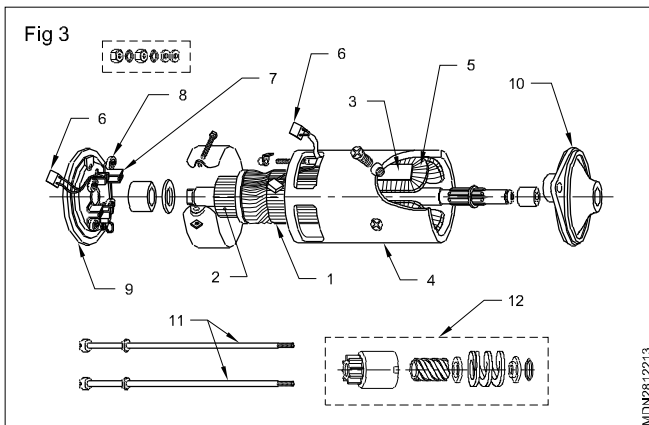

Once the engine starts running under its own power it attains a speed up to 4000 r.p.m. (depending upon the design). Since the flywheel ring to starter pinion ratio is very high, the starter pinion will rotate at a much higher speed than the engine. This speed will damage the starting motor by throwing the windings out of the armature slots and also the commutator segments due to centrifugal force. In order to prevent this it is necessary to disengage the starter pinion from the flywheel ring gear once the engine has started. To achieve this three types of drive mechanisms are used.

- Bendix drive
- Over-running clutch drive
- Axial or sliding armature type and non-coaxial type

Bendix drive

This is a most commonly used mechanism. It consists of a pinion (1) (Fig 4) which is mounted on a hollow sleeve. The pinion (1) has internal screw threads and is loose fitted on the sleeve (2). The armature shaft (3) is supported by bearings at both the ends. A bendix drive spring (4) is provided to limit the turning of the sleeve on the armature shaft. An anti-drift spring (5) is provided to prevent the pinion from striking the flywheel (6).

When the motor is switched on, the drive head rotates with the armature shaft (3). This motion is transmitted to the sleeve. The pinion (1) rotates along with the sleeve and travels forward to come in mesh with the flywheel ring gear (6). Now the engine's crankshaft rotates and the engine is started. When the engine speed increases the pinion (1) is thrown back to its original position due to inertia.

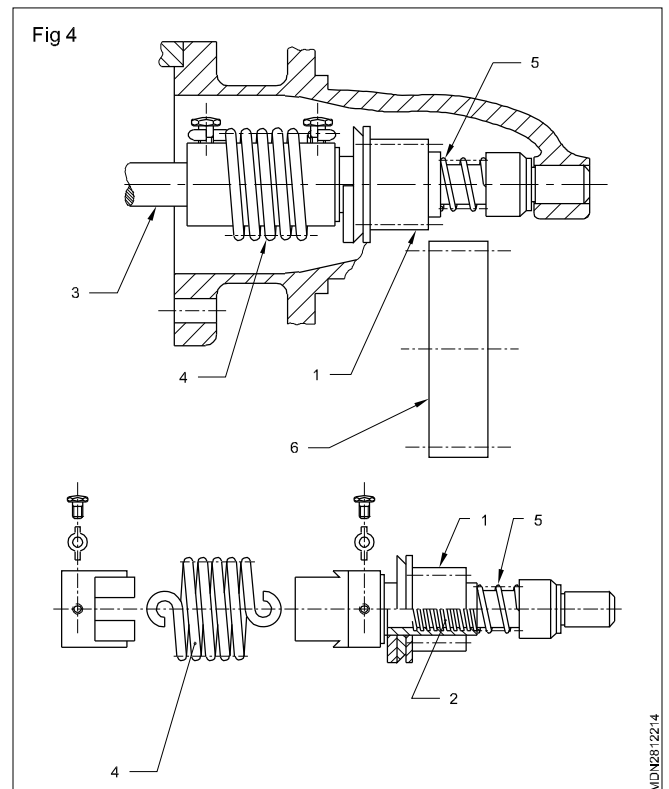

Over running clutch drive

The shift lever (2) is used by the over-running clutch to slide the pinion along the armature shaft (3) for meshing into or out of the flywheel teeth (4). The shift lever (2) is operated either by a solenoid (5) or by manual linkage. The over-running clutch permits the drive pinion (1) to run faster than the armature for a brief period during which the pinion (1) remains in mesh with the ring gear (4) once the engine has started. This protects the armature from damage due to over-speeding. (Fig 5 & Fig 6)

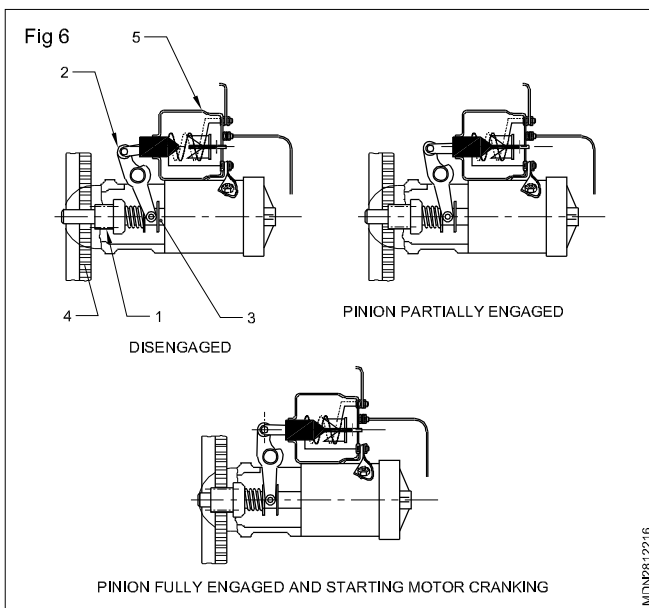
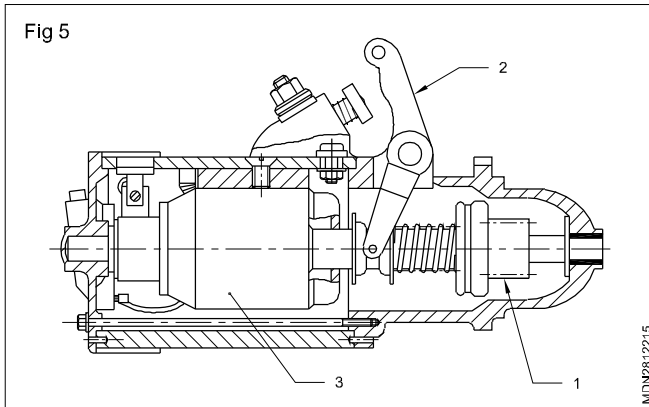

The over-running clutch, (Fig 7) which consists of a shell and a sleeve (1) assembly, is splined to the armature shaft (8), so that the shell is driven by the shaft.

The pinion gear (3) is fastened to a collar (9) which is fitted inside the clutch shell. Four tapered notches (4) cut in the shell contain steel rollers (5). These are held in the small ends of the notches by spring (7) and plunger assemblies so that the rollers contact the collar.

The pinion (3) is forced to rotate with the armature shaft and cranks the engine. When the engine starts its attempts to drive the armature shaft (8) cause the rollers (5) to rotate out of the small ends of the notches. This will release the collar (3) from the shaft. This allows the pinion (3) to rotate at high speed without driving the armature.

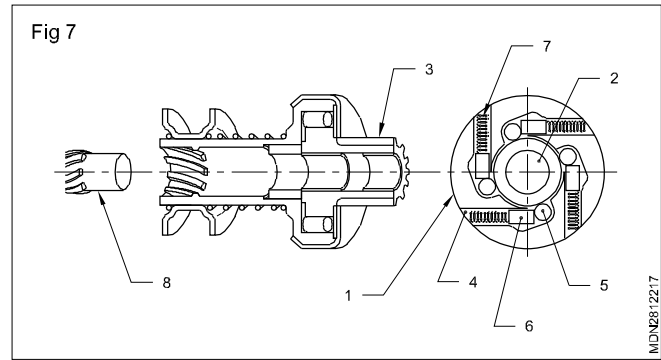

Axial or sliding armature drive

This type of drive allows its armature (1) (Fig 8) to slide in order to enable its pinion to come in mesh with the flywheel ring gear (2).

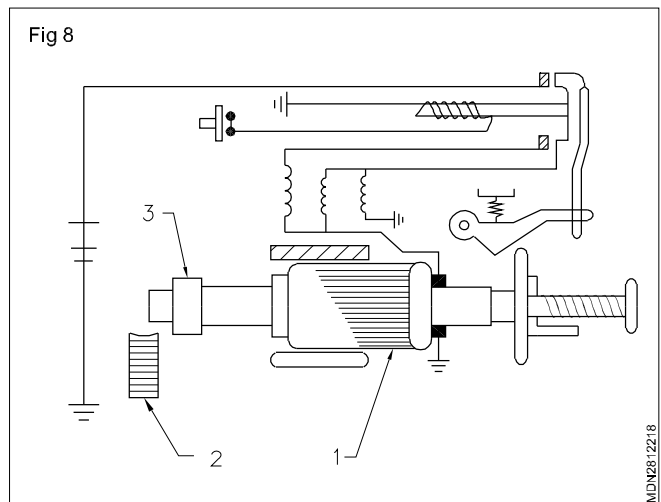

When the starter switch is operated, the solenoid coil is energised. This completes the circuit of the shunt winding and also of an auxiliary series field winding. The armature is pulled due to the magnetic field and the pinion (3) engages with the flywheel ring gear (2). A clutch is provided between the armature (1) and pinion (1). When the starter switch is released, the armature returns to its original position by the return spring. Since the pinion (1) is still in mesh with the flywheel (2).

It rotates at very high speed but the clutch prevents the rotation of the armature at the pinion's speed and prevents damage to the armature. The pinion is held in mesh until the starter switch is released by the auxiliary shunt winding. When the engine starts, the current falls down and the magnetic field is reduced. Now the pinion is pulled back to its position by the spring.

Need of solenoid switch

The solenoid switch is a strong electromagnetic switch. It is used to operate the over-running clutch drive pinion to engage with the flywheel ring gear. It also acts as a relay to close the contacts between the battery and the starting motor.

Construction of solenoid switch (Fig 9)

In a solenoid there are two windings, a pull-in winding (1) and a hold-in winding (2). The pull-in winding (1) is wound with thick wires (series winding) and the hold-in winding (2) is of thin wires (shunt winding). The pull-in winding (1) is connected to the starter switch (3) in the solenoid.

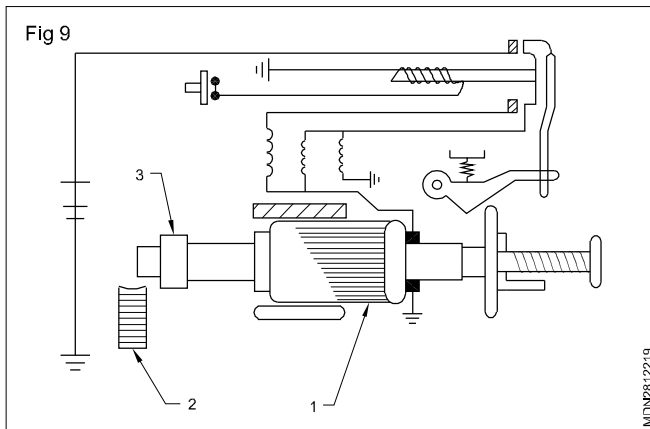

The hold in winding (2) is connected across the switch terminal and ground. The two windings are wound around a hollow core (4). An iron plunger (5) is placed inside the core (4).

The other end of the plunger moves a shift lever (7) to engage the pinion (8) with the flywheel ring gear (9).

Function of solenoid switch (Fig 10)

When the starter switch (3) is turned, current flows from the battery to the solenoid windings (1) and (2). This energises the windings which pull the plunger (5). The plunger (5) operates the shift lever (7) to engage the pinion (8) on the flywheel ring gear (9). Then it closes the circuit between the battery (10) and the starting motor.

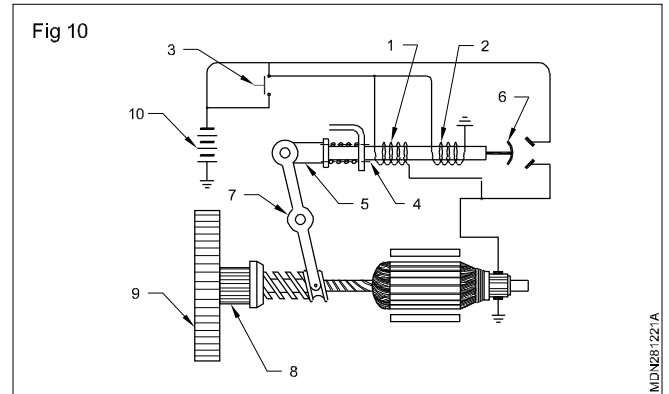

Common troubles and remedy in starter circuit

Troubles	Remedies
Heavy starter cable terminal worm unit solenoid coil defective sleeve operating lever bend	Replace Replace the solenoid Replace/Replace
Pinion gear teeth wornout	Replace the pinion
Arnature short circuit	Rewinding/Replace
Cummulator wornout	Reground/Replace
Carbon brush wornout	Replace
Carbon brush spring tension week	Replace
Field winding short circuited	Rewinding
Pinion gear returning spring broken	Replace
Starter motor mounting loose connection	tighten
Solenoud plunger jam	Check the fork lever
Plunger contact point pitted /burnt	Clean /Replace