

Fuel tank and fuel pipes

Objectives: At the end of this lesson you shall be able to

- **explain the function of the fuel tank**
 - **explain the function of each part of fuel tank**
 - **explain the function of fuel pipes.**
-

Fuel Tank

The Fuel tank is provided for storing diesel required for running the engine. It is constructed of either pressed sheet metal with welded seams and special coating to prevent corrosion or fiber glass reinforced plastic materials.

It may be round or rectangular in shape. It is mounted above the engine assembly.

Parts of the fuel tank

Filler neck and cap

Baffle

Fuel gauge sensing unit (Float)

Filter

Sediment bowl and drain plug

Filler neck is provided for pumping diesel into the fuel tank. A cap is provided for closing the tank tightly. A vent hole is provided either in filler neck or in cap to maintain atmospheric pressure in the tank above the fuel.

Fuel filter

Objectives: At the end of this lesson you shall be able to

- **state the need of a fuel filter**
 - **explain the types of fuel filter systems**
 - **explain the need for blending the fuel system**
 - **state the function of water.**
-

Need of fuel filter

Effective filtering of fuel, oil is most important for long trouble free functioning of the engine. Diesel fuel while transporting and handling has chances of getting contaminated by water, dirt, bacteria and wax crystals. Dirt is the worst enemy of the fuel injection equipment. Dirt contamination can be the result of careless filling of the fuel tank. When fuel tank is not filled, moist air condenses inside the metal wall of the fuel tank resulting in water contamination of the fuel.

For these reasons a very efficient filtering system is required to remove these impurities.

Baffles are provided in the fuel tank to minimize the slushing of fuel due to movement inside the tank.

Fuel gauge sensing unit is provided to know the level of fuel available in tank. It consists of a float resting on the surface of the diesel in the tank. The float with the help of the electrical sensing system indicates the level of the fuel available in the tank, on the dash board fuel-gauge.

Filter is provided at the lower end of the suction pipe. It filters heavy foreign particles.

At the bottom of the fuel tank a drain plug is provided to collect sediments and drain it out of the tank.

Fuel pipe

Fuel pipe between the fuel tank and the feed pump is called suction pipe, the pipes between F.I.P. and the injectors are called high pressure pipes. An over flow pipe is provided on fuel filter bowl and injectors to supply excess fuel back to fuel tank.

Types of fuel filter system

There are two types of fuel filtering system.

Single filter system

Two stage filter system

In a single filtering system one single filter assembly is used in between feed pump and fuel pump. The single filter in this system is capable of separating dirt from fuel. It should be replaced periodically as per the recommendations of the manufacturers.

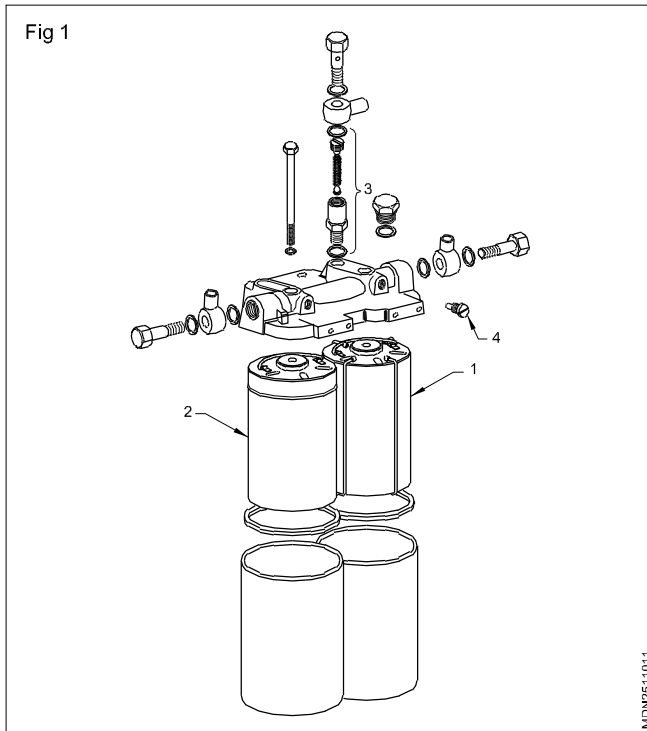

In a two stage filter system, primary filter (1) (Fig 1) is used for filtering large solid contaminants and most of the water in the fuel is also removed by this filter. The secondary filter (2) is made of a paper element. This filter controls the size of the particles allowed to pass into the fuel injectors. It also separates any water that might have passed through the primary filter. An overflow valve assembly (3) is used to send back excess fuel to fuel tank. A bleading screw (4) is provided to bleed the air from fuel system.

Fuel filter element

A paper element is most suitable because important properties which determine filter quality such as pore size and pore distribution can be effectively maintained. Generally paper filter elements are used at the secondary stage filtration process.

Coil type paper filter inserts are wound around a tube and neighbouring layers are glued together at the top and bottom. This forms a pocket with the openings at the top.

In the star type paper filter inserts, the fuel flows radially from outside to inside. The paper folds are sealed at the top and bottom by end covers.

Cloth type filter inserts are used for primary stage filtration. In this the fuel flows radially from outside to inside. The cloth is wound over a perforated tube whose ends are sealed at the top and bottom by end covers.

Bleeding of the fuel system

Bleeding is the process by which air, which is present in the fuel system, is removed. Air locking in the fuel system will result in erratic running of the engine and may result in stopping of the engine. Bleeding is carried out by priming

the filter. A slight loosening of the bleading screw allows locked air to escape as bubbles along with the fuel. When locked air escapes and the system is free of air, the screw is tightened finally.

Diesel fuel water separator

A fuel water separator is device that works to ensure clean fuel is delivered to the engine.

The fuel water separator is a small filtering device used to remove water from the diesel fuel before it reaches to the sensitive parts of the engine. Water and contaminants have a great impact on the service life and performance of diesel engines.

Besides being abrasive to engine components and cylinder walls, water and combination displaces diesel fuel lubrication coating on precision injector components, causing tolerance erosion, surface fitting, fuel loss and poor performance.

The first stage of the fuel water separator uses a plated paper element to change water particles into large enough droplets that will fall by gravity to a water sump at bottom of the filter. The second stage is made of silicone treated nylon that acts as a safety device to prevent small particles of water that avoid the first stage from passing into the engine. To remove the water from the fuel water separator, open the valve to drain the water from filter if the water separator fails, water in the fuel can wear away lubricants on the diesel fuel injectors so that fuel water separator is important part of fuel system.

Fuel water separator filter (FWSF)

Components of fuel water separator filter provide a better way to filter fuel and it has a twist fuel filter water separating system.

- Filter
- Water collection bowl
- Water drain valve with WIF sensor or threaded part

Benefits

- Protect engine components
- Extend equipment life

Features

It is easy to switch over water from fuel

- Water separating fuel filter with standard twist & drain.
- Water collection bowl for easy usual inspection.
- Alternative twist and drain valve with water in fuel (WIF) sensor or threaded port.

Fuel feed pump

Objectives: At the end of this lesson you shall be able to

- explain the function of a feed pump
- explain the construction of a feed pump
- explain the working of a feed pump.

Function

A feed pump is usually mounted on the F.I.P. and is driven by the camshaft of F.I.P. It sucks fuel from fuel tank and supplies it to fuel filters.

Construction

The fuel feed pump consists of a barrel, a plunger, a plunger return spring, spindle, roller tappet, suction and delivery valves, hand primer and pre-filter.

Working

The feed pump plunger (1) (Fig 1 & Fig 2) is driven by the cam (2) provided on the F.I.P. camshaft (3). When the plunger moves "downwards" by means of roller tappet (4) and pressure spindle (5) a portion of the fuel present in the suction chamber (6) is delivered through the pressure valve (7) to the pressure chamber (8) and the plunger spring (9) compressed in an intermediate stroke. Towards the end of this stroke the spring loaded pressure valve closes again.

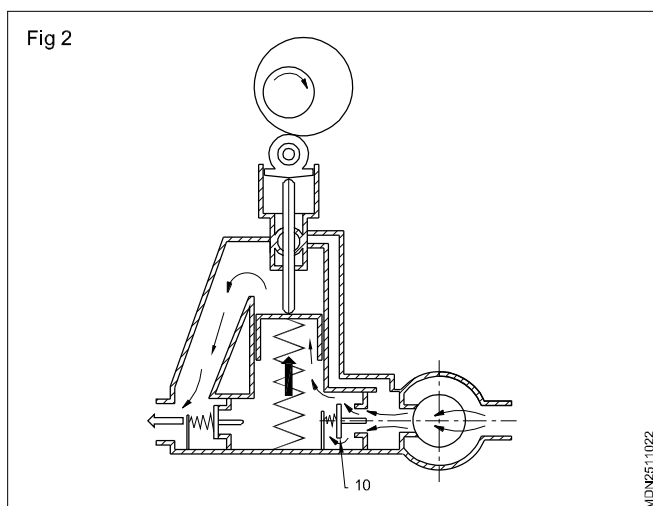
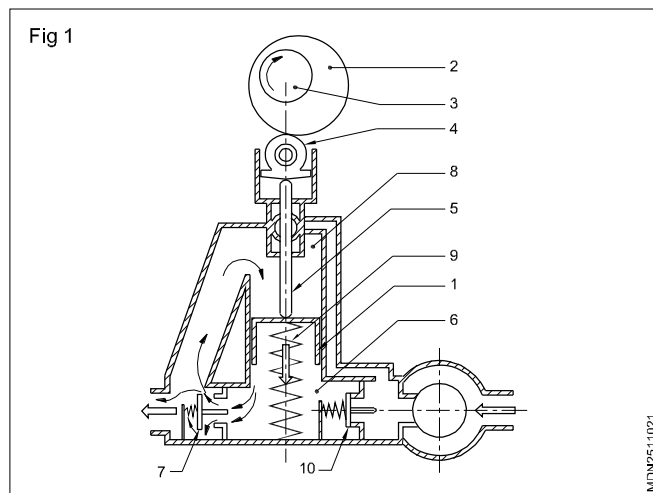

As soon as the cam or eccentric has passed its maximum stroke, plunger, pressure spindle and roller tappet move "upward" due to the pressure exercised by the plunger spring. A portion of the fuel present in the pressure chamber is thereby delivered to the fuel injection pump through filter. However, fuel is sucked simultaneously from the fuel tank to the suction chamber through the primary filter provided in the feed pump and suction valve (10).

When the pressure in the feed pipe exceeds a specified, pressure the plunger spring lifts the plunger only partially. The quantity of fuel delivered per stroke in this is comparatively smaller. When the fuel pipe line is full and the F.I.P. does not need further fuel the feed pump should be put out of action. Due to the excess fuel in the fuel outlet line the pressure in the pressure chamber, holds the plunger in the top position putting the feed pump out of action. During this period only spindle works. The moment the pressure falls down the spring forces the plunger down and the pumping action is resumed. This action during which fuel is not supplied by feed pump is known as idling of feed pump.

Hand priming device

The hand priming device is screwed into the feed pump above the suction valve. When the engine is at rest, with the aid of the hand priming device fuel can be pumped from the fuel tank through the filter to the F.I.P. In order to operate the primer the knurled knob is screwed out until the plunger can be pulled upwards causing the suction valve to open for fuel to flow into the suction chamber.

When the plunger is pressed down the suction valve closes while the pressure valve opens and fuel flows through the feed pipe and the filter to the F.I.P. After the use it is essential to screw the knob again in its original position.

Preliminary strainer

The preliminary strainer is usually attached to the feed pump. The function of the preliminary strainer is to prevent the coarser impurities at a very early stage. It consists of a housing with a nylon/wire gauge insert or a wire mesh sieve.

Fuel injection pump

Objectives: At the end of this lesson you shall be able to

- explain function of F.I.P.
- explain constructional features of F.I.P.
- state the need of calibration
- list out types of fuel injection system
- explain air injection and airless injection
- state the need of a governor
- list out different types of governors
- explain constructional features of governors
- explain operation of governor
- explain specifications shown on F.I.P. plate.

Function of the F.I.P.

Fuel Injection Pumps are designed to deliver specific quantity of fuel to the combustion chamber through an injector at a specific time.

Types of F.I.P.

There are two types of F.I.P.

Inline pump

Distributor or rotary type pump.

The inline pump has a plunger and barrel assembly for each cylinder of the engine. The assemblies are grouped together in one housing that resembles cylinders of an engine block.

Distributor or rotary type of fuel injection pump has a single pumping element, which supplies fuel to all the cylinders. Distribution to the individual injector is effected by a rotor having a single inlet and delivery, in turn to the appropriate number of outlets. This is done with the help of rotor. Cylindrical plungers and drilled holes in the bore.

Working of a F.I.P.

When the plunger (1) (Fig 1) is at its bottom position fuel enters through the barrel's (2) inlet port from the feed pump, fills the space above the plunger in the barrel and excess fuel flows out through the spill port. In a primed system, the barrel (2), all the pipes and the entire system is filled with the fuel. As the plunger rises up due to cam operation, certain amount of fuel is pushed out of the barrel through the ports. As soon as the ports are closed by the plunger, the flow of fuel is stopped and the fuel above the plunger in the barrel is trapped and is pressurized. The pressure increases to as high as 400 to 700 bar (kgf/cm²).

This pressure lifts the fuel delivery valve (3) and the fuel enters the fuel line (6) which is connected to the injector. As the pipe is already full of fuel the extra fuel which is being pumped causes a rise in the pressure throughout the line and lifts the injector valve. This permits the fuel to be sprayed into the combustion chamber in a fine mist form. It continues until the lower edge of the helical groove in the plunger uncovers the port in the barrel. As soon as the port

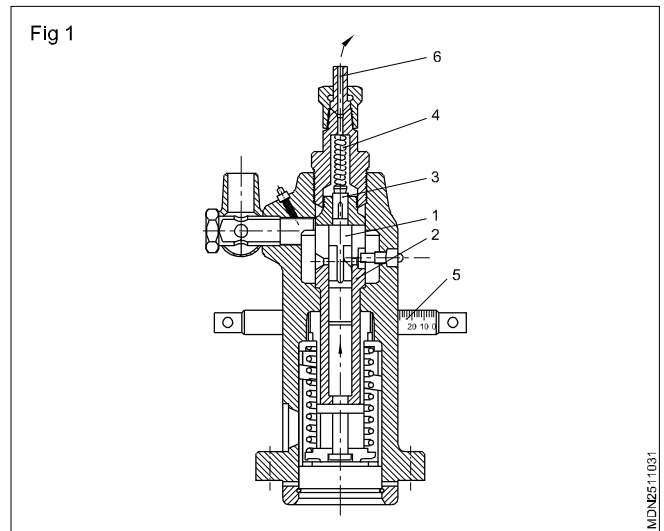

is uncovered, the fuel by passes downwards through the vertical slot and flows to the port. This causes a drop in pressure and delivery valve closes under its springs (4) pressure. With the consequent drop in the fuel line the injector valve also closes and cuts off the fuel injection.

The plunger stroke is always constant. But by rotation of the plunger in the barrel, it is possible to deliver the fuel earlier or later in the stroke and control the quantity of fuel sprayed. (As shown in Fig 2) The rotation of the plunger is obtained by operating the control rack (5), which is in turn connected to the governor.

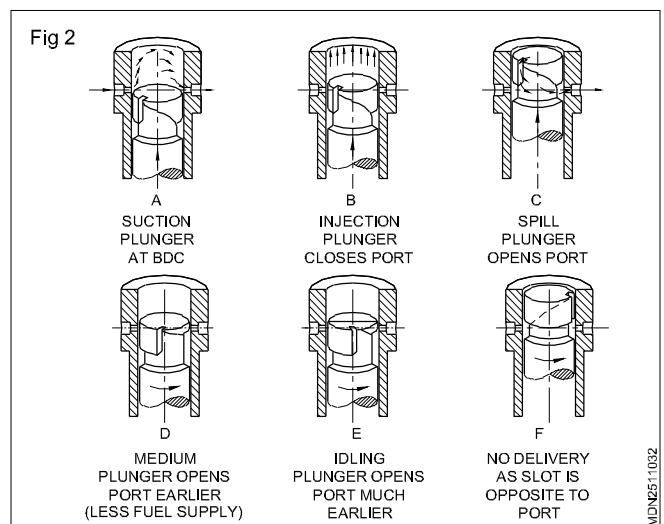

The governor controls all engine speeds upto a maximum, according to pedal pressed by driver. Different positions of the plunger and the fuel flow is given in the figure.

Constructional features of distributor type F.I.P.

It has a single pumping element which supplies fuel to all cylinders. The distribution to the individual injector is effected by a rotor having a single inlet and delivery equal to the number of cylinders. This ensures in built and uniform delivery to all injectors.

The pumping element consists of two plain opposed cylindrical plungers in a diametrical hole in the rotor head, an extension of which forms the distributor. An axial hole (1) (Fig 3) drilled in this extension connects the pumping chamber with a raked hole which registers in turn with raked delivery ports (2) due for each cylinder of the engine.

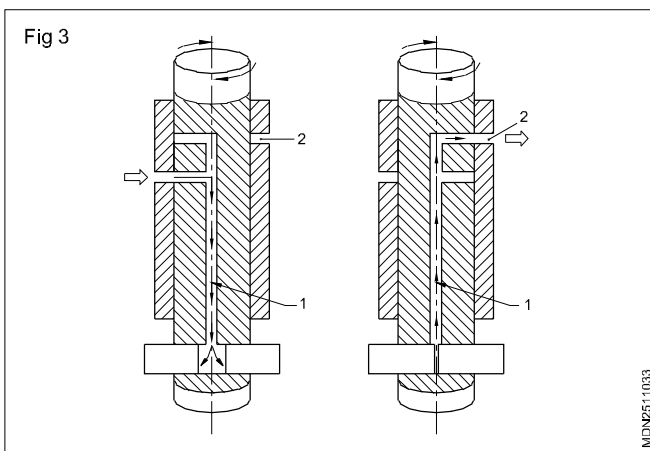

Need for calibration

In a multi cylinder engine it is necessary that equal and specified quantity of fuel is supplied to each cylinder by fuel injection pump at specified time. The measurement of fuel delivered by each plunger with the control rod in a fixed position and its comparison is called calibration of F.I.P. The adjustment for varying the fuel delivery can be done by altering the position of the control sleeve of each plunger. It is achieved by calibrating the F.I.P. on a test bench by a correct chart as recommended by the manufacturer.

Phasing is the process of testing the pump for the accuracy of their supplying fuel at correct intervals.

Types of fuel injection system

There are two types of fuel injection system for diesel engines.

Air blast injection.

Mechanical injection.

Air blast injection

In the air blast injection system, a high pressure air blast drives the fuel at a very high velocity into the cylinder where it is mixed with the compressed air in the cylinder and ignites.

Mechanical injection

In mechanical fuel injection system, fuel is forced in from a mechanical fuel injection pump through injectors. These are of two types -

Low pressure fuel supply system.

Metering injection system.

All fuel supply systems use the same components, although the components vary in size and location within the system.

Low pressure fuel supply system

The low pressure fuel supply system consists of one or more fuel tanks, a feed pump, fuel filters, hand priming pump, overflow valve and a return orifice.

Metering injection system

It consists primarily of injection pump and injector and categorized as below, depending on the metering system.

(i) Pump controlled system

This is operated with a high pressure plunger and metering mechanism

(ii) Unit injectors system

This system is similar to the pump controlled system except that the high pressure pumping and metering mechanism are an integral part of the fuel injector.

(iii) Common rail system

This type of system uses a high pressure fuel pump that is connected to a common fuel rail. Each cylinder's fuel injector is connected to the common fuel rail.

Governors

The governor is a device for holding any speed steady between idling and maximum speed. The fuel injection pump operates in conjunction with a governor, which is required to control the injected quantity of fuel so that the engine neither stalls when idling nor exceeds the maximum speed for which it is designed.

Following Types of Governors are used

Mechanical

Pneumatic

Servo

Hydraulic

Mechanical Governor

Mechanical governors have speed measuring mechanism and fuel controlling mechanism actuated by mechanical arrangement. Two fly weights (Fig 4) (1) are mounted to the governor's drive gear or directly fastened to the camshaft. The centrifugal force of the fly weights actuates the fuel control mechanism.

Cooling and lubrication

The single-plunger injection pump can be mounted in any position. In operation, its interior is completely filled with Diesel fuel under slight pressure in order to prevent intrusion of air and dust; and also to prevent rust formation caused by condensation. Excess fuel is recirculated within the pump to provide adequate cooling and lubrication.

Nozzles

Objectives: At the end of this lesson you shall be able to

- explain function of injectors
- list out different types of injectors
- explain special features of various types of nozzles
- explain specification of nozzle and nozzle holder.
- explain cumming & detrit diesel injection
- state the functioning of glow plug.

Fuel Injectors Fig 1

The function of the fuel injector is to deliver finely atomized fuel under high pressure to the combustion chamber for the engine. All component parts of the injector are carried in nozzle holder 10. The main part of the injector is the nozzle comprising nozzle body 12 and nozzle valve 11. The nozzle body and needle valve are fabricated from alloy steel. They are thoroughly machined and have high surface finish necessary for operation in condition of high temperatures and elevated pressures. The bore in the nozzle body and the nozzle needle valve are lapped to a close tolerance and are a matched set, so that neither the nozzle body nor the needle valve may be replaced individually. The needle valve is pressed against a conical seat in the nozzle body by spring 4 acting through the intermediary of stem 8. The spring pressure, hence injection pressure, is adjusted by adjusting screw 2. The adjusting screw is screwed in the bottom of the injector spring cap nut which in turn is screwed in the nozzle holder. Lock nut 3 is used to prevent the adjusting screw from unscrewing spontaneously. The screw is covered by nozzle holder cap nut 1 provided with a threaded hole to connect the leak-off pipe through which the leak-off fuel (used to lubricate the nozzle valve) filling the pressure spring and adjusting screw area is returned to the fuel tank or the secondary fuel filter.

In operation, fuel from the injection pump enters pressure chamber (gallery) 15 in the nozzle body through supply passage 9 and a high-pressure pipe. When the fuel pressure in the pressure chamber becomes so high that the force acting on the pressure taper of the needle valve

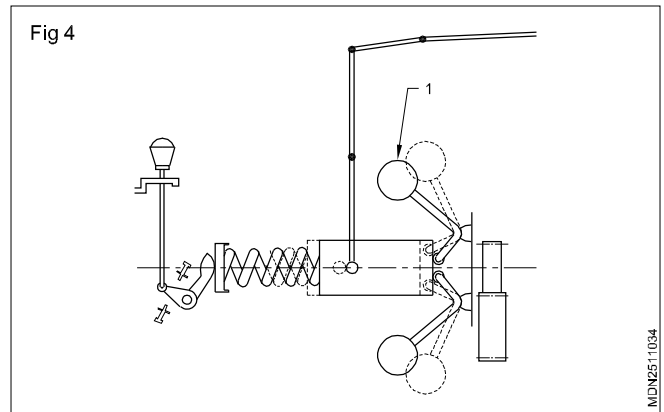

from below exceeds the set spring force on the stem, the needle valve lifts off its seat and comes to rest with its upper shoulder against the face of the nozzle holder. Fuel is then forced out of the nozzle spray holes into the combustion chamber in a spray pattern which depends on the type of nozzle used.

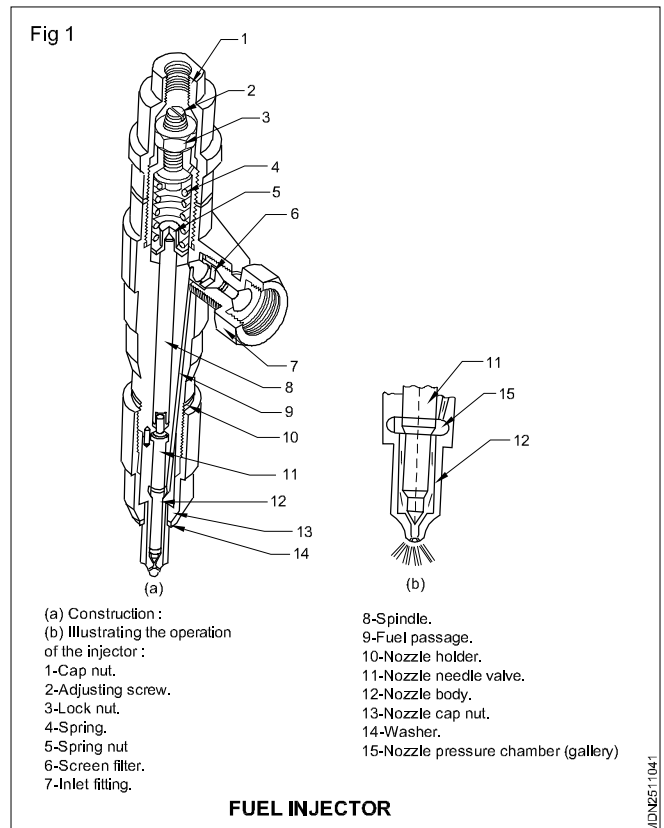

After the injection of fuel has been ended, the fuel delivery from the injection pump ceases, the pressure in pressure chamber 15 of the nozzle drops instantly, and the pressure spring snaps the needle valve onto its seat, preventing unpressurized fuel from leaving the nozzle. The fuel injector is installed in a brass injector tube, or sleeve, which is fitted in a hole in the cylinder head, and is held in place by a special clamp.

Injectors are provided to atomise the fuel into engine cylinder. This is done to achieve complete combustion.

Following types of nozzles are used in engine.

- Single hole type (Fig 2)
- Multihole type (Fig 3)
- Longstem type (Fig 4)
- Pintle type (Fig 5)
- Delay nozzle (Fig 6)
- Pintaux nozzle (Fig 7)

Single hole type

In this type, one hole is drilled centrally or in an angle through its body which is closed by nozzle valve.

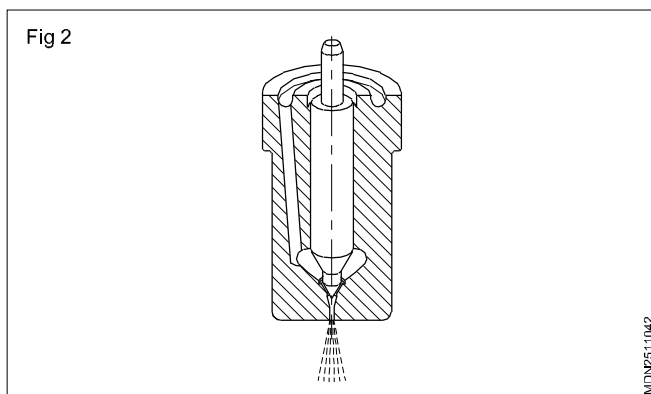

Multihole type

In this type varying number of holes are drilled at the end of the body. The actual number of holes depend upon the engine requirement.

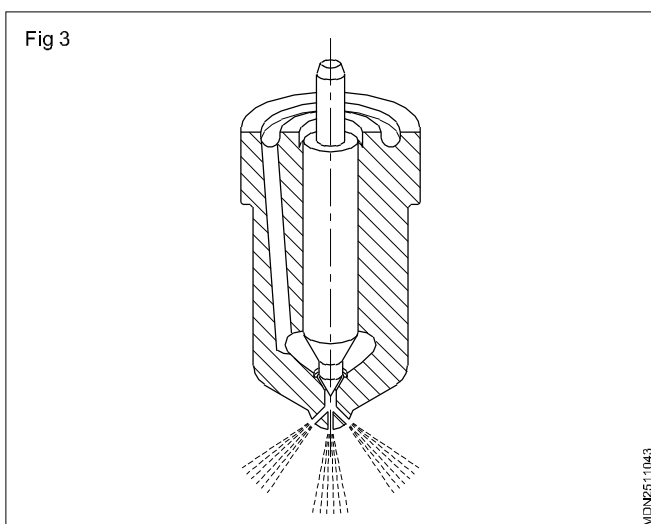

Longstem type

For providing adequate cooling for the standard short stem nozzle, a different type of nozzle with a small diameter extension has been developed. This is called long stem nozzle.

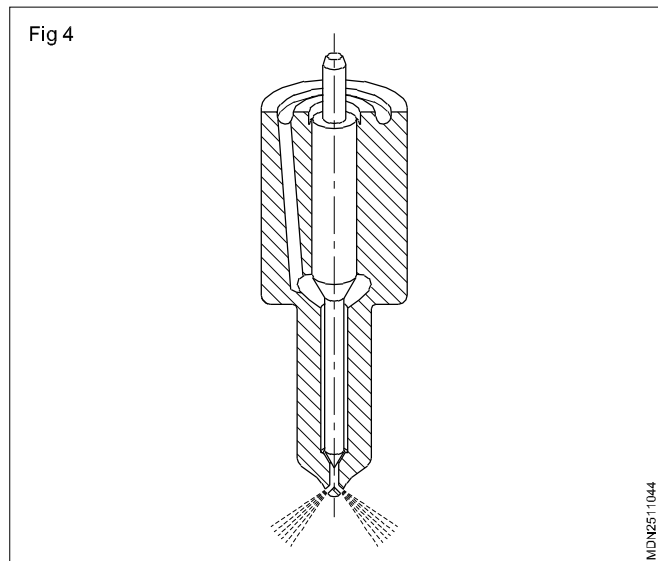

Pintle type

In this type the valve stem is extended to form a pin or pintle which protrudes through the mouth of the nozzle body.

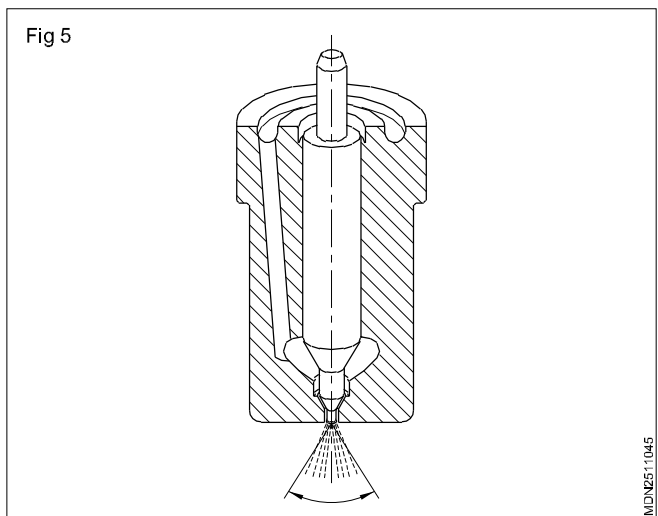

Delay nozzle

In this type spray pattern is controlled by the modification in pintle design. This will reduce the amount of fuel in combustion chamber, when the combustion begins. This modified nozzle is known as delay nozzle.

Pintaux nozzle

This is the further development of pintle type nozzle, having an auxillary spray hole to assist easy starting under cold condition.

Fig 6

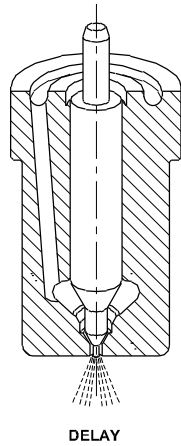

INDN2511046

Fig 7

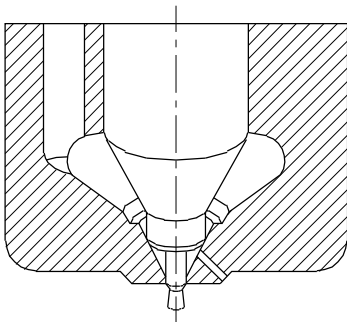

INDN2511047

Need

A heater plug or glow plug is used in a Diesel engine having a pre-combustion chamber for igniting the diesel fuel spray. This arrangement makes for an easy starting of a diesel engine in cold weather. Most diesel engines use heater plugs. Figure 9 shows parts of a heater or glow plug.

Description of a glow plug (Fig 8)

Fig 8

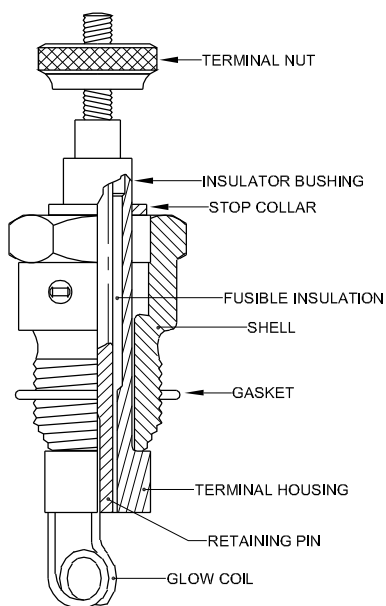

CONSTRUCTION OF THE DUAL - POLE GLOW PLUG

INDN2511048

The glow plug consists of a heating element (glowing coil) and is provided with an insulator shell and other parts. One such glow plug is shown in Fig 9. In a multi-cylinder engine the number of glow plugs depends on the number of cylinders. They are connected in series (Fig 10), parallel with the battery, through a glow plug switch, (control switch) a resistor and a red indicator light and they are provided on the dashboard (panel) of the vehicle. The glow control switch is a three-way one, connecting to the starter also for starting purposes. The glow control switch serves to connect and disconnect the battery with the glow plug as and when required. The red indicator light indicates to the driver, the working of the glow plug or its failure.

Working of the circuit (Fig 9)

When the switch is closed, the heating element becomes very hot due to the passage of current from the battery, and the surrounding air is heated up. When the engine is cranked heated air is drawn into the cylinder giving the compressed air a higher temperature for ignition. The fuel particles, which happen to be very near the hot air, will be ignited directly, thus initiating combustion. After combustion begins, the burning air-fuel mixture comes out of the pre-combustion chamber and enters into the main chamber. There it gets mixed up with the combustion chamber air and thus combustion is completed.

Precautions

- After the engine is started the glow plug is to be cut off from the circuit. Otherwise the glow coil will be heated up additionally and gets burnt up eventually, resulting in the replacement of the glow plug.
- The glow plug switch should not be operated for more than three seconds.
- The glow coil is having low electrical resistance and hence it will be very hot when connected to the circuit. Do not touch it, when it is hot.

Detroit diesel cummins diesel

Detroit diesel cummins diesel well known for favouring unit injectors, in which the high-pressure pump is contained within the injector itself. This leads to the development of the modern unit injector.

Cummings PT (pressure-time) is a form of unit injection where the fuel injectors are on a common rail fed by a low-pressure pump and the injectors are actuated by a third lobe on the camshaft. The pressure determines how much fuel the injectors get and the cam determines the time.

Design of the unit injector eliminates the need for high-pressure fuel pipes, and with that their associated failures, as well as allowing for much higher injection pressure to occur. The unit injector system allows accurate injection timing, and amount control as in the common rail system.

The unit injector fitted into the engine cylinder head, where the fuel supplied via integral ducts machined directly into the cylinder head. Each injector has its own pumping element, and in the case of electronic control, a fuel

solenoid valve as well. The fuel system is divided into the low pressure <5 bar fuel supply system, and the high-pressure injection system <2000 bar.

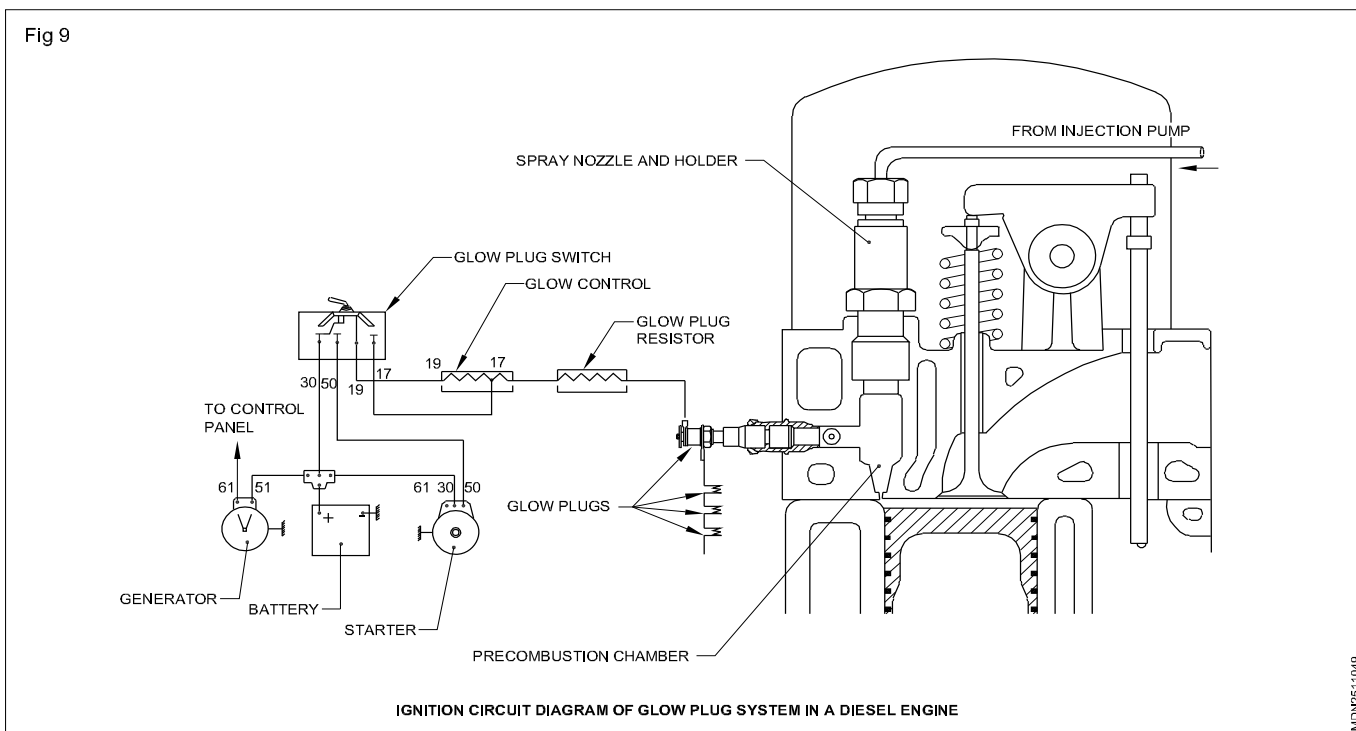

Electronic diesel control (EDC) system

Objective: At the end of this lesson you shall be able to
• **state the function of electronic diesel control device.**

Electronic diesel control Fig 1 is a diesel engine fuel injection control system for the precise metering and delivery of fuel into the combustion chamber of modern diesel engines used in trucks and cars.

The electronic control, the system which provides greater ability for precise measuring, data processing environment flexibility and analysis to ensure efficient diesel engine operation.

- It receives the information from sensor, analyze/ calculate it and sends the instructions to the actuators.
- It converts information from analog to digital.
- It consists of microprocessors to process the information from sensor to ECM and ECM to actuators.
- Number of microprocessors are depends upon the number of sensors and actuators.
- It also consists of memory to store the data.
- Speed is in the form of 8 Bit, 16 Bit, 32 Bit, 64 Bit etc., to pass the information from sensor to ECM, ECM to actuator and also in networking system.
- Individual programmes have to be made for each sensor and actuator.



Note: Move the below figure under the common rail direct injection system (Fig 2)

Main control systems in diesel engine

- It controls the fuel for idling.
- It controls the fuel for high speed.
- It controls the fuel according to the speed and load conditions.
- It controls the exhaust gas recirculation (EGR) valve.

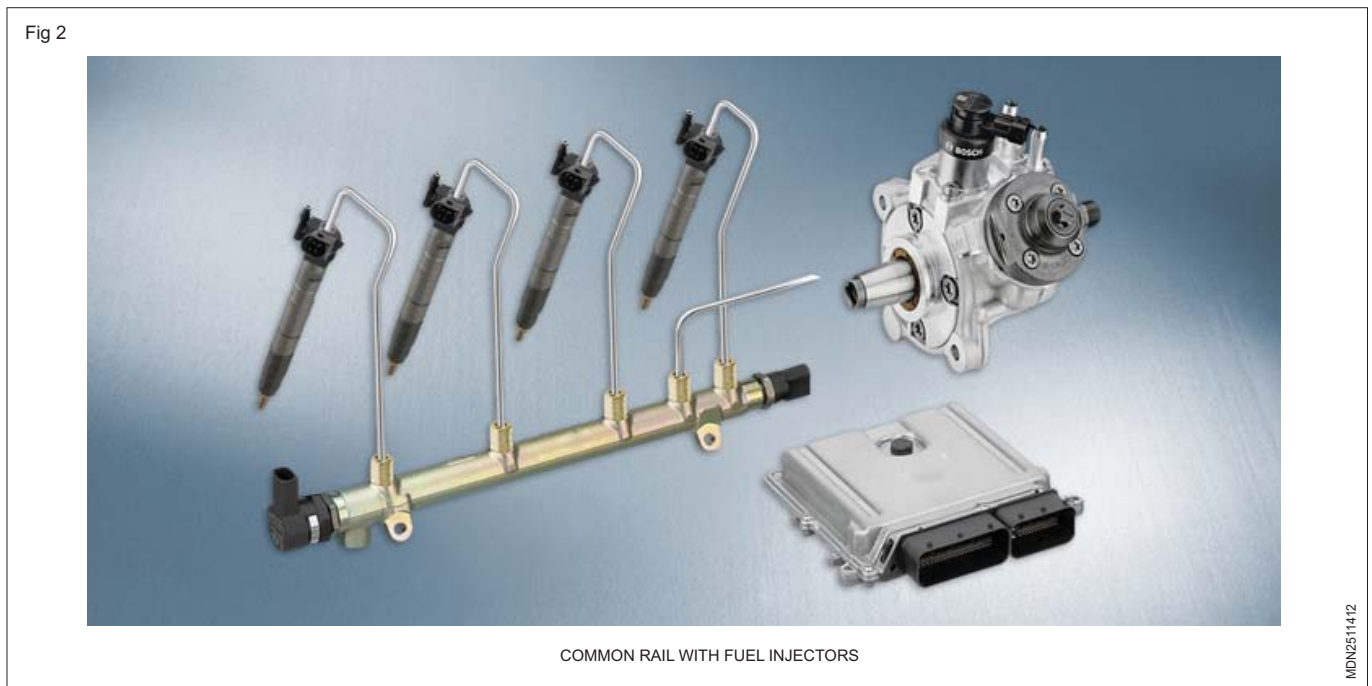

Working

It gets the input from the different sensors named are as follows.

- 1 Throttle position **TP** (intake air quantity)
- 2 Cam position **CMP** (for valve timing)
- 3 Crank position **CKP** (for RPM and firing order)
- 4 Engine coolant temperature **ECT** (Cylinder temperature)
- 5 Inlet air temperature **IAT** (temperature of inlet air)
- 6 Manifold absolute pressure **MAP** (inlet air pressure)
- 7 Oxygen **O2** (percentage of oxygen in exhaust gas)

After receiving the above inputs, it analyzes/calculates the amount of fuel is required for the cylinder, accordingly it supplies the voltage to the injector solenoid. The solenoid will open the injector to supply the fuel into the combustion chamber. The minimum injector opening period is 1/10th second.

Minimum 3 important sensors (TP, CKP & CMP) inputs are required at the time of starting, if any one of the sensor fails, engine does not start.

Rest of the sensors (IAT, ECT, MAP, and O2) fails; engine will start but the performance of the engine will affect.

Note:

- **In a vehicle minimum one EDC/ECM is required**
- **More than one EDC/ECM are used depends on number of controls.**

Example of control units EDC/ECM in a vehicle

- 1 Engine management
- 2 Automatic transmission
- 3 Power steering
- 4 SRS (Air Bag) supplemental restraint system
- 5 ABS (Antilock braking system)

Exhaust gas recirculation (EGR) EGR valve allows the exhaust gases into the inlet manifold, to burn the unburn gases to reduce the emission.

The opening angle of the valve is controlled by the EDC, depending upon the amount - (%) of oxygen passing through exhaust gases.

EDC gets the percentage of oxygen from the oxygen sensor.

Sensor

It senses the information in the form of physical or chemical variables and sends that information to the ECM in the form of voltage i.e. between 0-6 volts or 0-12 volts.

Ex: Throttle valve opening position (angle) information sends to the ECM in the form of voltage.

ECM

It analyzes or calculates the information which have come from the sensors and gives the instruction to the actuators.

Ex: It supplies the current to the solenoid to open the injector opening duration depends on Inputs

Actuators:

Based on instructions from the ECM, it does the mechanical work.

Ex: Injector opening duration depends on ECM instruction.

Schematic layout system components

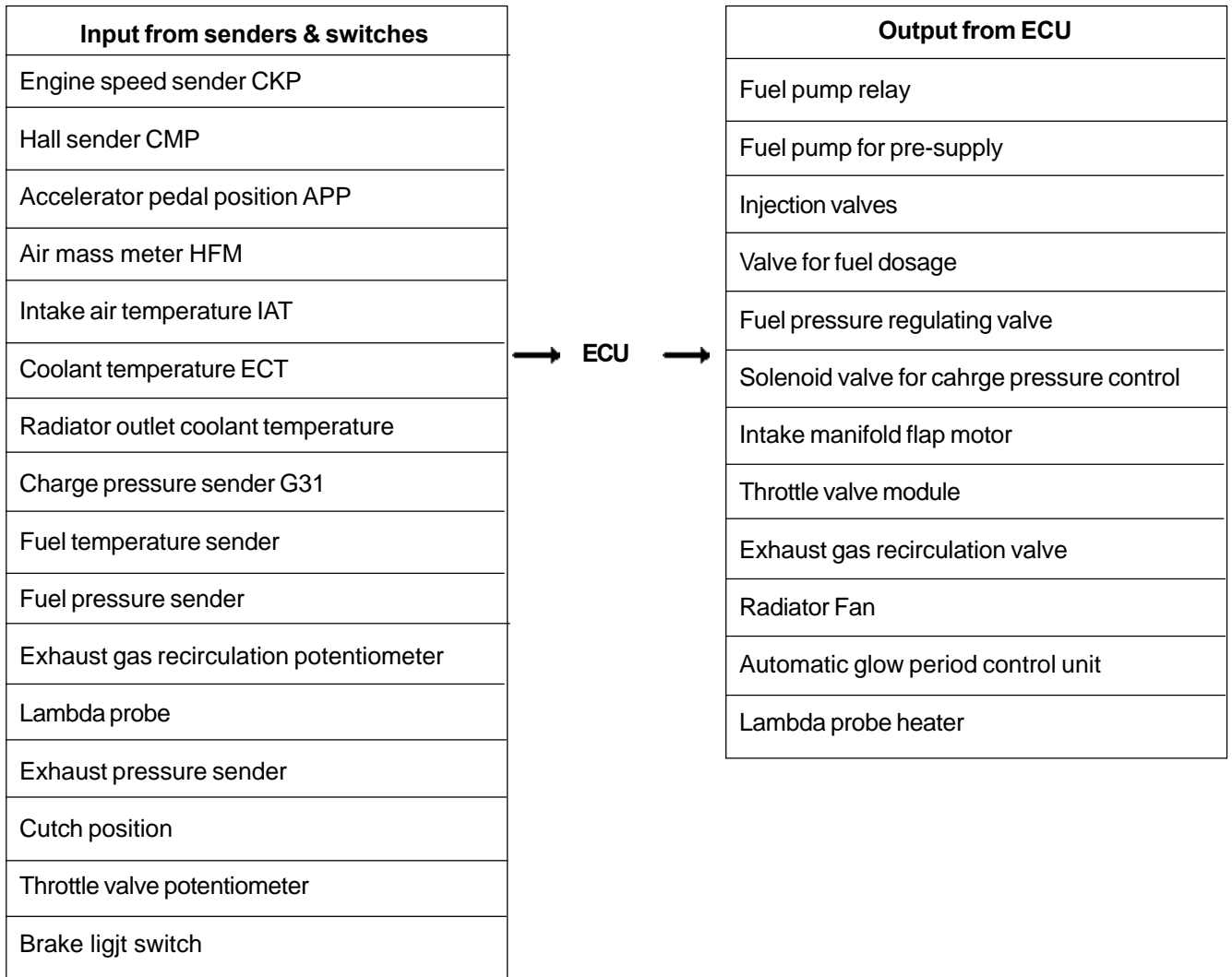

ECM Electronic control module (or) system

Objectives: At the end of this lesson you shall be able to

- describe E.C.M Electronic control module (or) system
- state various control devices
- explain the fuel injection control system
- explain the fuel pump control system
- explain the injection control system
- explain the radiator fan control system.

Electronic control system

The electronic control system consist of various sensors which detect the state of engine and driving conditions, ECM which controls various devices according to the signals from the sensors and Various controlled devices.

The systems are

- Fuel injection control system
- Idle speed control system
- Fuel pump control system,
- Radiator fan control system,

Idle speed control system

This system controls the bypass airflow by means of ECM & IAC valve for the following purposes. To keep the engine idle speed as specified at all times. The engine idle speed can vary due to load applied to engine, to improve starting performance of the engine to compensate air fuel mixture ratio when -decelerating, to improve drivability while engine is warmed up. IAC valve operates according to duty signal sent from ECM. ECM detects the engine condition by using the signals from various signals and switches and controls the bypass airflow by changing IAC valve opening. When the vehicle is at a stop, the throttle valve is at the idle position and the engine is running, the engine speed is kept at a specified idle speed.

Fuel pump control system

ECM controls ON/OFF operation of the fuel pump by turning it ON, the fuel pump relay under any of the conditions. For two seconds after ignition switch ON. While cranking engine (while engine start signal is inputted to ECM). While crankshaft position sensor or camshaft - position sensor signal is inputted to ECM.

Common rail diesel injection CRDI

Objectives: At the end of this lesson you shall be able to

- describe the construction of CRDI
- explain the working of the CRDI
- list out the merits and demerits of the CRDI.

Construction and working of CRDI system (Fig 1 & 2)

The common rail consists of fuel tank, electrical fuel pump (low pressure) in placed inside the fuel tank, It develops pressure upto 6 bar and supplies to the high pressure fuel pump (CRDI) through fuel filter and water separator. The high pressure fuel pump develops pressure 200 to 2000 bar and supplies to the common rail and common rail to fuel injectors inject fuel into the combustion chamber. Fuel injector are operator by ECM through solenoid valve. Common rail consists of fuel pressure regulator rail pressure

sensor and fuel pressure regulator supplies the excess amount of fuel to the fuel tank (≤ 1 bar pressure) Common rail will distribute the fuel to all the cylinder with equal pressure, Rail pressure will give the information of existing fuel pressure in the common rail. then all cylinders will develop uniform power, which will reduce vibration and noise of the engine.

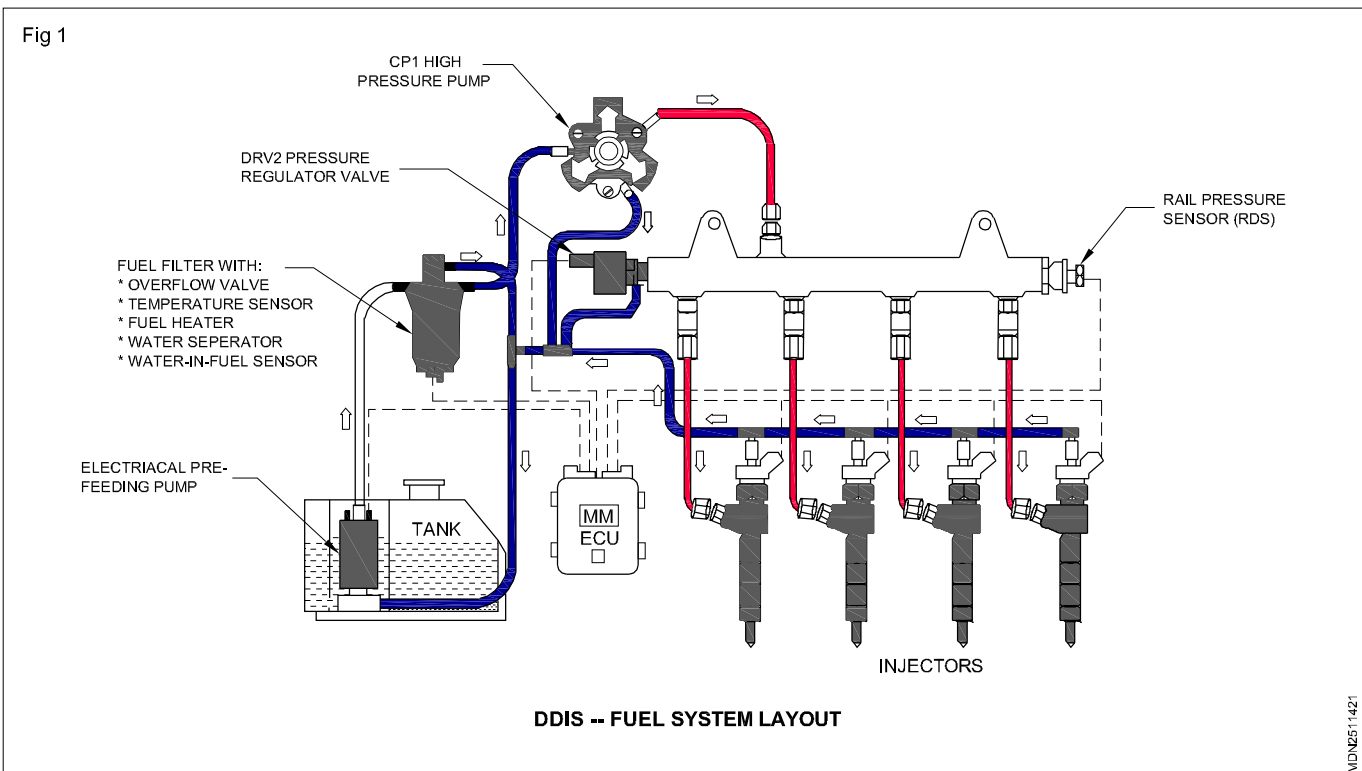
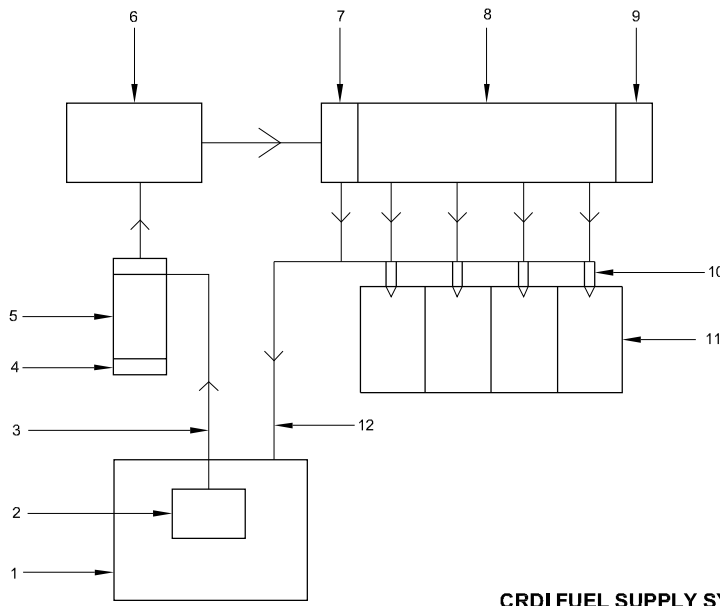

Fig 2



1. FUEL TANK
2. ELECTRICAL FUEL PUMP
3. FUEL SUPPLY LINE
4. WATER SEPARATOR
5. FUEL FILTER
6. HIGH PRESSURE FUEL PUMP (CRDI PUMP)
7. FUEL PRESSURE REGULATOR
8. COMMON RAIL
9. FUEL RAIL PRESSURE SENSOR
10. FUEL INJECTOR
11. ENGINE
12. FUEL RETURN LINE

CRDI FUEL SUPPLY SYSTEM

MIDN2511422

HEUI Hydraulically actuated electronically controlled unit injector

Objectives: At the end of this lesson you shall be able to

- describe the HEUI (Hydraulically Actuated Electronically Controlled Unit Injector)
- explain basic components
- explain its working principle
- advantages of HEUI.

HEUI (Hydraulically Actuated Electronically Controlled Unit Injector)

HEUI Fuel System represents one of the most significant innovations in diesel engine technology in the diesel technology. HEUI made easy of many limitations of mechanical and conventional electronic injectors, and sets new standards for fuel efficiency, reliability and emission control. The highly sophisticated HEUI system uses hydraulic energy instead of mechanical energy to operate fuel injectors. Working along with the engine's ECM (Electronic Control Module), the HEUI system provides extremely accurate control of fuel metering and timing, so that it ensures unmatched engine performance and economy.

Unmatched engine performance and economy.

In the traditional common rail fuel system, the entire fuel line is under high pressure. With the HEUI system, fuel remains at low pressure until it is injected into the cylinder. Fuel pressure is created hydraulically in response to a signal from the Electronic Control Module (ECM).

The HEUI fuel system consists of four basic components:

HEUI (Fig 1) Injector Uses hydraulic energy (as opposed to mechanical energy from the engine camshaft) from pressurized engine lube oil for injection. The pressure of the incoming oil (800 to 3300 psi) controls the rate of injection, while the amount of fuel injected is determined by the ECM.

Electronic Control Module (ECM) This sophisticated on-board computer precisely manages fuel injection and other engine systems. The HEUI injector solenoid is energized by an electronic signal generated in the ECM. Using input from multiple sensors, the ECM's dual microprocessors use proprietary software and customer supplied performance parameters to produce maximum engine performance under any conditions.

High Pressure Oil Pump The variable displacement axial pump features a built-in reservoir to immediately supply oil at cold starts.

Injector Actuation Pressure Control Valve This electronically operated valve controls oil pump output and injection pressure.

Working principle

HEUI is divided in two sections. One is low pressure fuel chamber. Another one is high pressure oil chamber, fuel is supplied at low pressure and oil is supplied at high pressure to the respective chamber.

At the time of injections allows the high pressure oil in to the injection body and actuates the intensifier. The intensifier in turn pressurizes the diesel on the other side of it. So that the intensifier pressurizes seven times of the oil pressure and increases the pressure of the diesel. After then the injector lifts the spindle and injects the diesel through the holes of an injector.

Improved fuel economy The ability to inject fuel at any crank angle results in up to 2.7 percent better fuel economy compared to scroll mechanical injectors. Optimum fuel economy also means reduced gaseous emissions and less white smoke during cold engine starts.

Optimum performance The control of fuel delivered during ignition delay and main injection, known as rate shaping, is made possible by the HEUI's ability to operate independent of engine speed. Rate shaping modifies engine heat release characteristics, which also helps reduce emission and noise levels. Rate shaping optimizes engine performance by varying the idle and light load rate characteristics independent of rated and high load conditions.

Reduced smoke and particulate emissions

Since the HEUI injector's performance does not depend on engine speed, it can maintain high injection pressures through a wide operating range. Electronic control of these pressures helps improve emissions and low-speed engine response.

Reduced engine noise A split injection feature leads to a more controlled fuel burn and lower noise levels. Additional benefits include reduced shock loads as well as less wear and tear on drive train components.

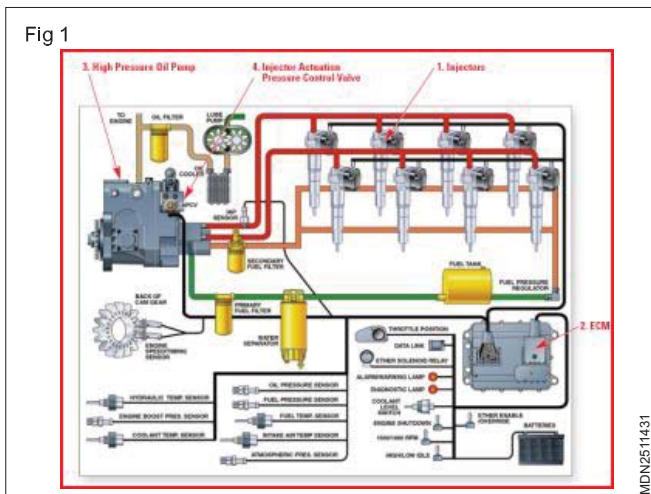

Sensors

Types of sensors

- 1 Engine coolant temperature (ECT)
- 2 Manifold absolute pressure (MAP)
- 3 Inlet air temperature (IAT)
- 4 Oxygen (O₂)
- 5 Throttle position sensor (TP)
- 6 Cam position (CMP)
- 7 Crank position (CKP)
- 8 Anti-lock braking system (ABS)

The above sensors are being used for the engine management system.

Recently one more sensor is added i.e ABS

Apart from the above so many other sensors are using in the vehicle.

In idest vehicles 10 to 100 plus sensors are using.

Classification & working principle of sensors

Switches

Resistive sensor

Current generating sensor

Hall effect sensor

Hot film air mass meter

Lambda sensor

Switches (Fig 2)

Switches are basically on-off sensors & the input given to ECU is normally in two states i.e either "ON" or "OFF" physical position of the switch can be change by operating condition like temperature, pressure, external force etc.

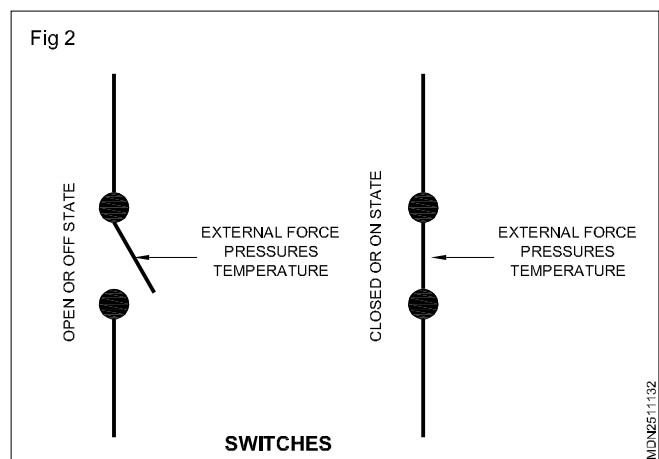

Resistive sensor (Fig 3)

In resistive sensor the variation is resistance happens due to change in input data like position, temperature pressure etc. Input to the control unit is not necessarily the resistance but can be the voltage also.

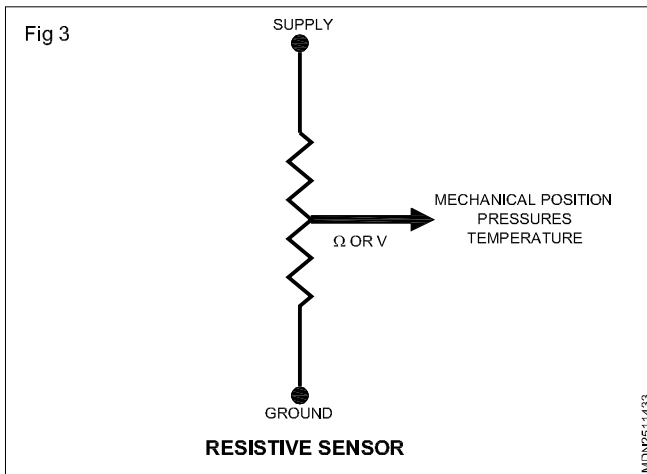

Types of resistive sensor

1 Rheostat (Fig 4)

Generally 2 wire sensor. Change is resistance happen due to change in mechanical position. Value of resistance or voltage is interpreted by ECU for calculation. Measurement of value happen inside the control unit.

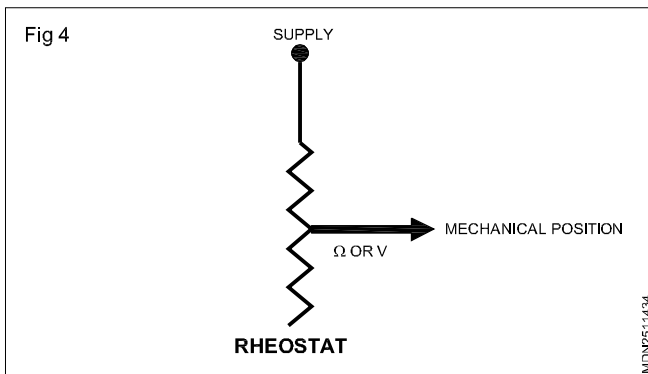

2 Potentiometer (Fig 5)

Generally 3 wire sensor. Change is resistance happen due to change in mechanical position. Value of voltage is interpreted by ECU for calculation. Measurement of value happen outside the control unit.

3 Thermister (Fig 6)

Thermister are those sensors whose resistance value changes due to change in temperature. Thermister are supplied with constant voltage. Out put voltage changes due to change in resistance which is continuously monitor by control unit to decide the temperature value. Thermister can have either negative temperature co efficient [NTC] or positive temperature co efficient [PTC].

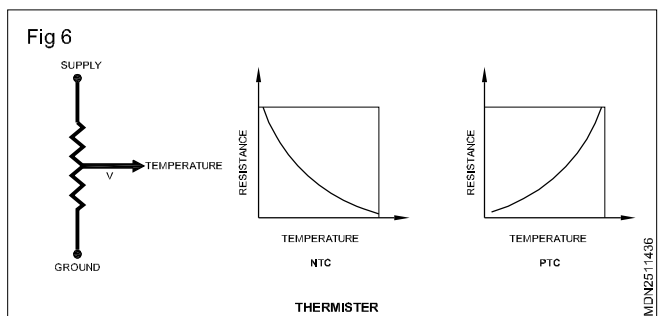
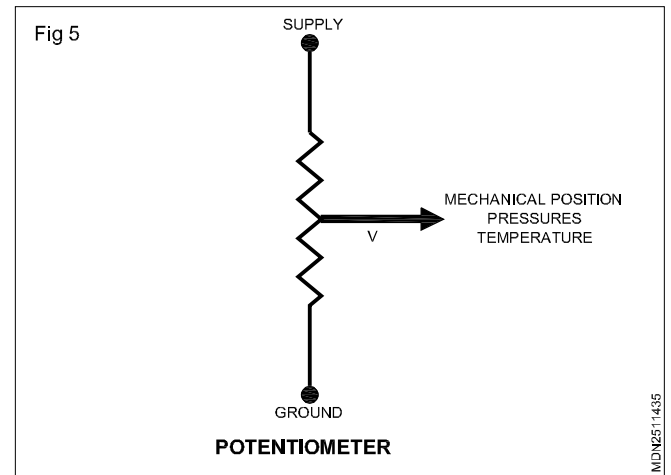

4 Piezo resistive sensor (Fig 7)

Piezo resistive sensors are those whose resistance changes die to change in pressure. They are subjected to external pressure which causes change in resistance. Constant voltage is supplied & out put voltage changes due to change in pressure which is interpreted by control unit to decide the pressure value.

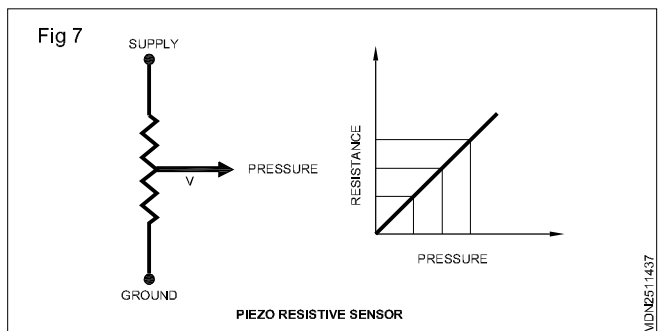

5 Current generating sensor

Certain sensors generate the voltage when subjected to change is physical phenomenon such as pressure, position etc. They are mainly classified as follows.

- 1 Piezo electric sensor
- 2 Magnetic induction sensor

6 Piezo electric sensor (Fig 8)

Certain crystal such as quartz when subjected to a pressure generate potential difference on its surface. The phenomenon is reversible.

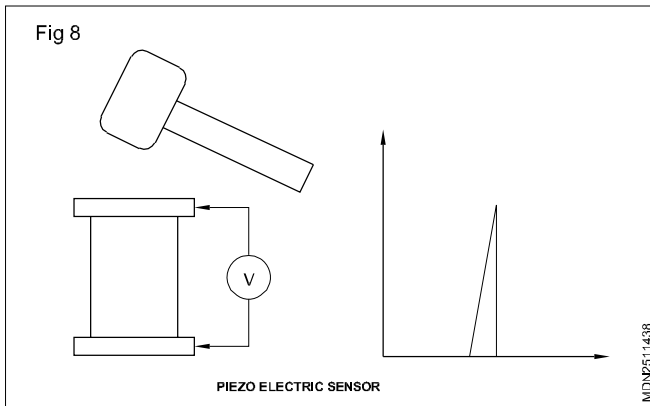

7 Magnetic inductive sensor (Fig 9)

This kind of sensor are consist of coil wound around the permanent magnet. When the magnetic filed is disturb by external means current is generated inside the coil terminals. The pattern of current obtained is depends on the kind of disturbance produce.

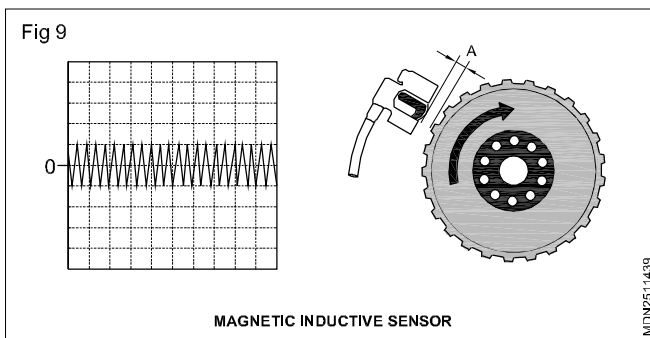

8 Hall effect sensor (Fig 10)

When a current passes through the semiconductor plate there is no current develop at right angles to the direction of current. However when this plate is subjected to a magnetic filed, voltage is developed at right angles to the direction of current. The magnitude of this voltage is proportionate to the magnetic field through the semiconductor.

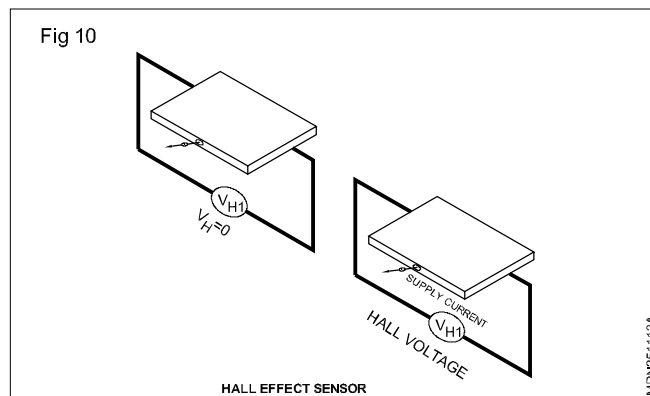

9 Hot film air mass meter (Fig 11)

This sensor is used to measure the air flow in engine management system. It consist of measuring tube & sensor electronic with sensor element. The sensor element consist of heating resistors, two thermister R1 & R2, & intake air temperature sensor.

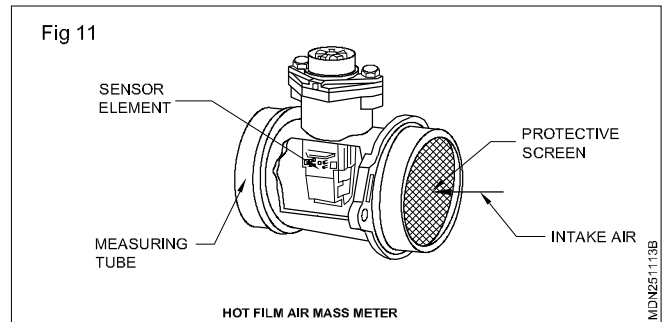

10 Sensors & actuators (Fig 12)

Sensors element is heated at constant temperature appr. 120°C above intake air temperature. Due to air flow there is a temperature difference at R1 & R2. This difference is recognized by electronic module & the intake air mass is calculated. THis also decide the direction of air flow.

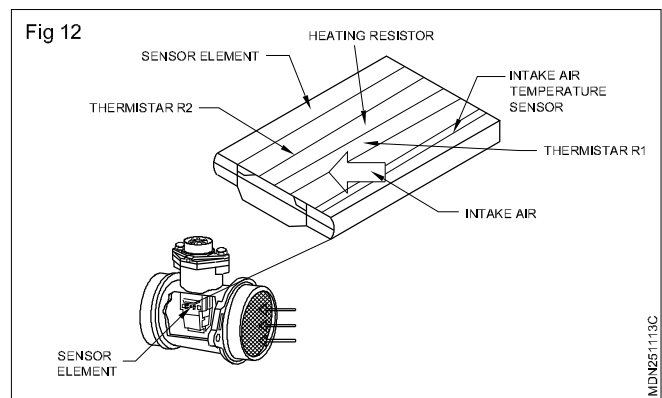

11 Lambda (oxygen) sensor (Fig 13)

This sensor is normally used in petrol engine to decide the oxygen content in exhaust gas. Based on the input from this sensor the ECU do minor correction to the amount of fuel being metered.

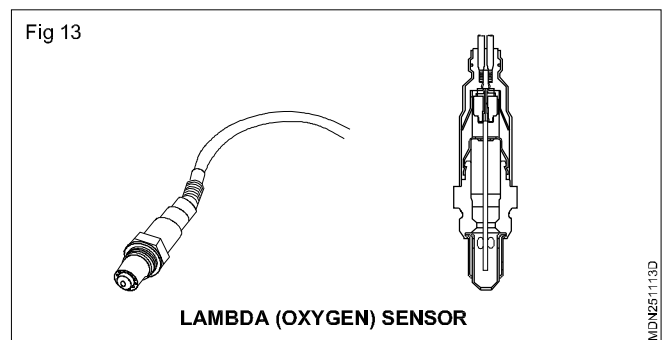

12 Lambda (oxygen) sensor (Fig 14)

The difference in oxygen content between the exhaust gas & ambient air causes a change in the electrical voltage within the probe. A change in the composition of the air fuel mixture produces a sudden voltage change by which $\lambda = 1$ can be identified.

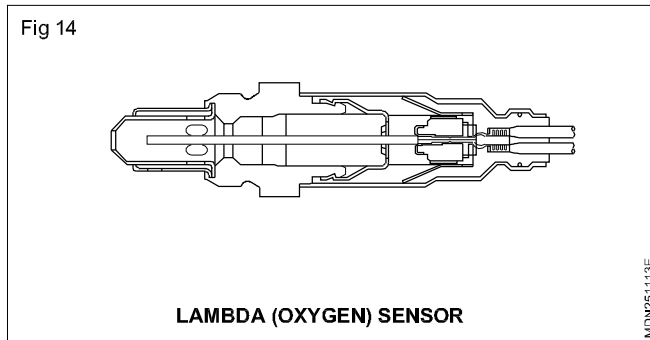

13 Sensors & actuators (Fig 15)

In connection with OBD II, second lambda sensor is connected after catalytic converter. It test correct functioning of the catalytic converter.

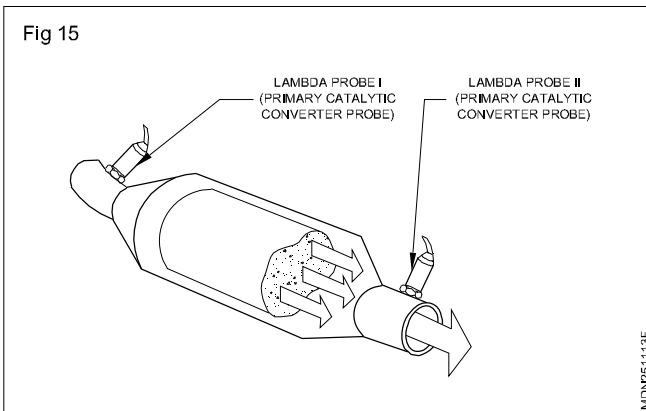

Actuators

- 1 Injectors
- 2 Power windows
- 3 Wiper motors
- 4 Relays etc

Number of actuators depends upon the devices to be operated.

14 Relay (Fig 16)

A relay is an electrically operated switch. many relays use an electromagnet to operate a switching mechanism mechanically, but other operating principles are also used. Relays are used where it is necessary to control a circuit by a low-power signal (with complete electrical isolation between control and controlled circuits), or where several circuits must be controlled by one signal.

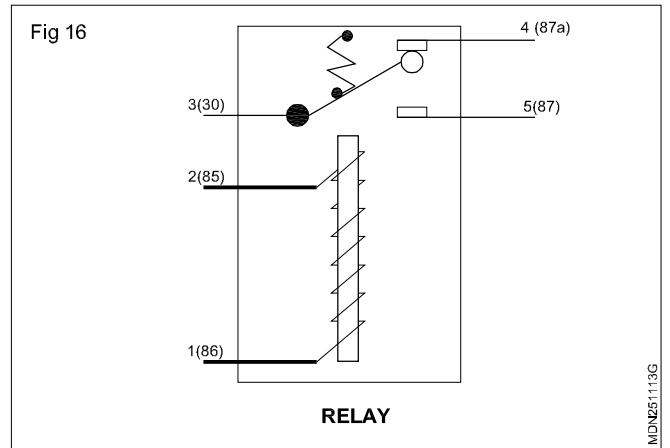

- 1 **Control circuit:** Control the operation which are activated by control unit or switch. It required very less power to activate. (Fig 17)
- 2 **Power circuit:** Connected to the load. Main current flows through this circuit. (Fig 17)

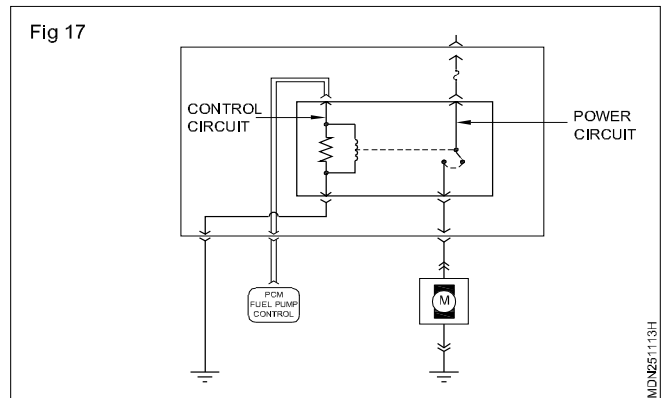

- 1 **Normally open relay [NO]:** (Fig 18) Power circuit is in open position. Circuit closes when control circuit is activated.
- 2 **Normally close relay [NC]:** (Fig 18) Power circuit is in close position. Circuit opens when control circuit is activated.

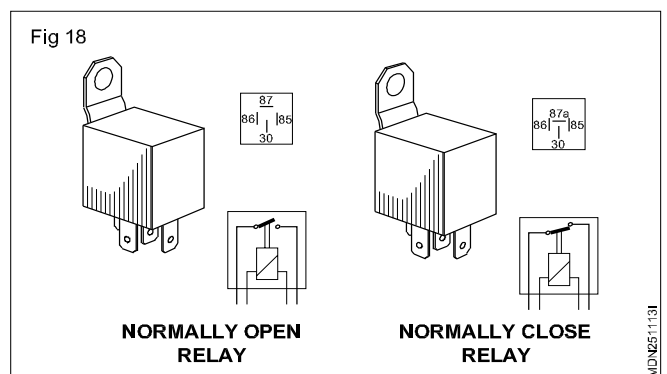

Working principles of actuators

DC Motors

Solenoid (Fig 19)

A solenoid is an electromechanical switch/ valve that is controlled by an electric current. The electric current runs through a solenoid, which is a wire coil wrapped around a metallic core. A solenoid creates a controlled magnetic field when an electrical current is passed through it. This magnetic field affects the state of the solenoid valve, causing the valve to open or close.

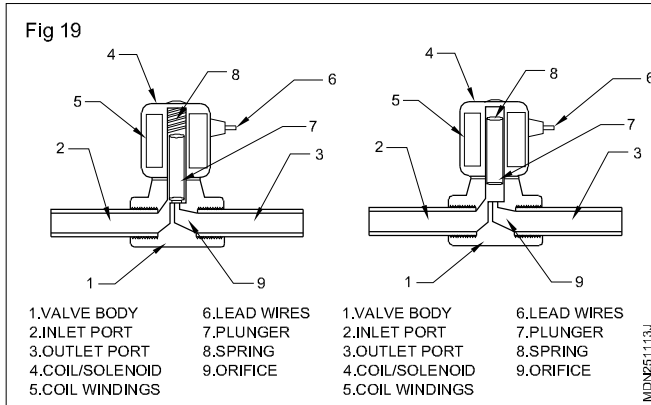

Stepper motor (Fig 20)

Stepper motors provide a means for precise positioning and speed control without the use of feedback sensors. The basic operation of a stepper motor allows the shaft to move a precise number of degrees each time a pulse of electricity is sent to the motor. Since the shaft of the motor moves only the number of degrees that it was designed for when each pulse is delivered, you can control the pulses that are sent and control the positioning and speed. The rotor of the motor produces torque from the interaction between the magnetic field in the stator and rotor. The strength of the magnetic fields is proportional to the amount of current sent to the stator and the number of turns in the windings.

